

① Fitted depending on features

Designation GV451 N/O mit FRZ, WW	LCS EN	Document No. 5600 0000137679	Rev A	Sheet-No. 1 of 1
		Material No. 9000190408		

# Customer service test programme

## 1. Selecting the model coding:

- Turn the rotary switch (S0) to position “5”.
- Press main switch and hold down for at least 3 sec.
- The current model coding is displayed via LEDs L1 – L3 for as long as the main switch is held down.

## 2. Reading out the fault memory:

- When the main switch is released, the special programme “P0” Read out fault memory is selected.
- After 5 sec. the fault memory of the last rinse cycle is displayed via LEDs L1 – L3.
- If **no** fault occurred in the last 8 rinse cycles, LEDs L2 and L3 flash slowly (0.5 Hz)

### Only control units with display:

- If **no** fault occurred in the last 8 rinse cycles, LEDs L2 and L3 flash slowly (0.5 Hz) and “E0” is displayed. **No** other fault memory can be read out.
- If a fault was detected, the fault memory of the last 8 rinse cycles can be read out by pressing and releasing one of the buttons S1 or S2. When the button is pressed, the rinse cycle is displayed and when the button is released, the associated fault (see table) is displayed.

## 3. Starting the customer service test programme

- Read out from the fault memory position, turn the rotary switch (S0) clockwise to position “6”
- The customer service test programme starts automatically
- LED L3 flashes during the customer service test programme
- The current position in the customer service test programme is displayed (only control units with display)
- Each change in state of the position switch for the water points is indicated by all LEDs lighting up briefly (function test of the LEDs and the position switch)
- A fault which has occurred is indicated immediately via the display or the LEDs L1 – L3 (heating fault after 60 minutes)
- If several faults occur, only the fault with the highest value is displayed
- Following each repair a customer service test programme must be run to detect any other faults.

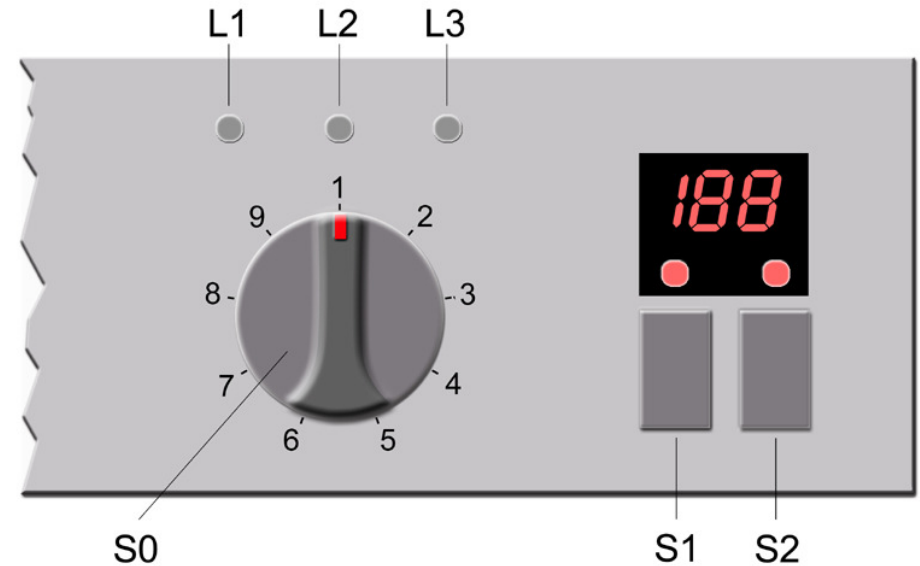

Document No. 56000000136755 ASP EN A	Rev. A	Sheet-No. 1 of 2
Material No. 9000 176 252	GV451, N / O, WE, WW, DS	

**Fault code:**

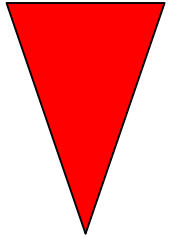
Fault code with display	Fault code without display			Fault type	Value
	L1	L2	L3		
E01	○	○	●	Heating fault	
E02	○	●	○	NTC fault	
E03	○	●	●	Filling fault	
E04	●	○	○	Water points cannot be positioned	
E05	●	○	●	- - -	
E06	●	●	○	Fault at the Aquasensorsystem or equipment variant without Aquasensor (no fault)	
E07	●	●	●	- - -	

○ = LED off    ● = LED flashes quickly (2 Hz)

**Sequence of the customer service test programme:**

Pos.	Function	Temperature	Capacity	Time (s)	Symbol
00	P			15	P = Pump
01	FWW		1,5 l		FWW = Fill soft water
02	PA			5	U = Circulate
03	FWW + U + reversal relay/auxiliary winding (SICASYM)		2,4 l	X	H = Heat
04	U + H + ZR	max. 72 °C		120	ZR = Dispense detergent
05	U + H	60 °C			ZK = Dispense rinse aid
06	U + H + R	max. 72 °C		120	R = Regeneration valve
07	U + ZK			120	AS_KAL = Calibrate Aqua sensor
08	AS_KAL_IR				WP = Alternating pump
09 -14	WP			30	SP = Intermittent pump
15	P			45	X = Calculated refill time
16	FWW			60	F = Filling
17-22	SP			30	
23	P			30	
0	End				

If the rotary switch (S0) is turned clockwise during the customer service programme, it is possible to jump to the next position.

The filling positions are an exception!

Document No. 56000000136755 ASP EN A	Rev. A	Sheet-No. 2 of 2
Material No. 9000 176 252	GV451, N / O, WE, WW, DS	

The reproduction, transmission or use of this document or its contents is not permitted without express written authority. Offenders will be liable for damages. All rights including rights created by patent grant or registration of a utility model or design are reserved. Copyright reserved.

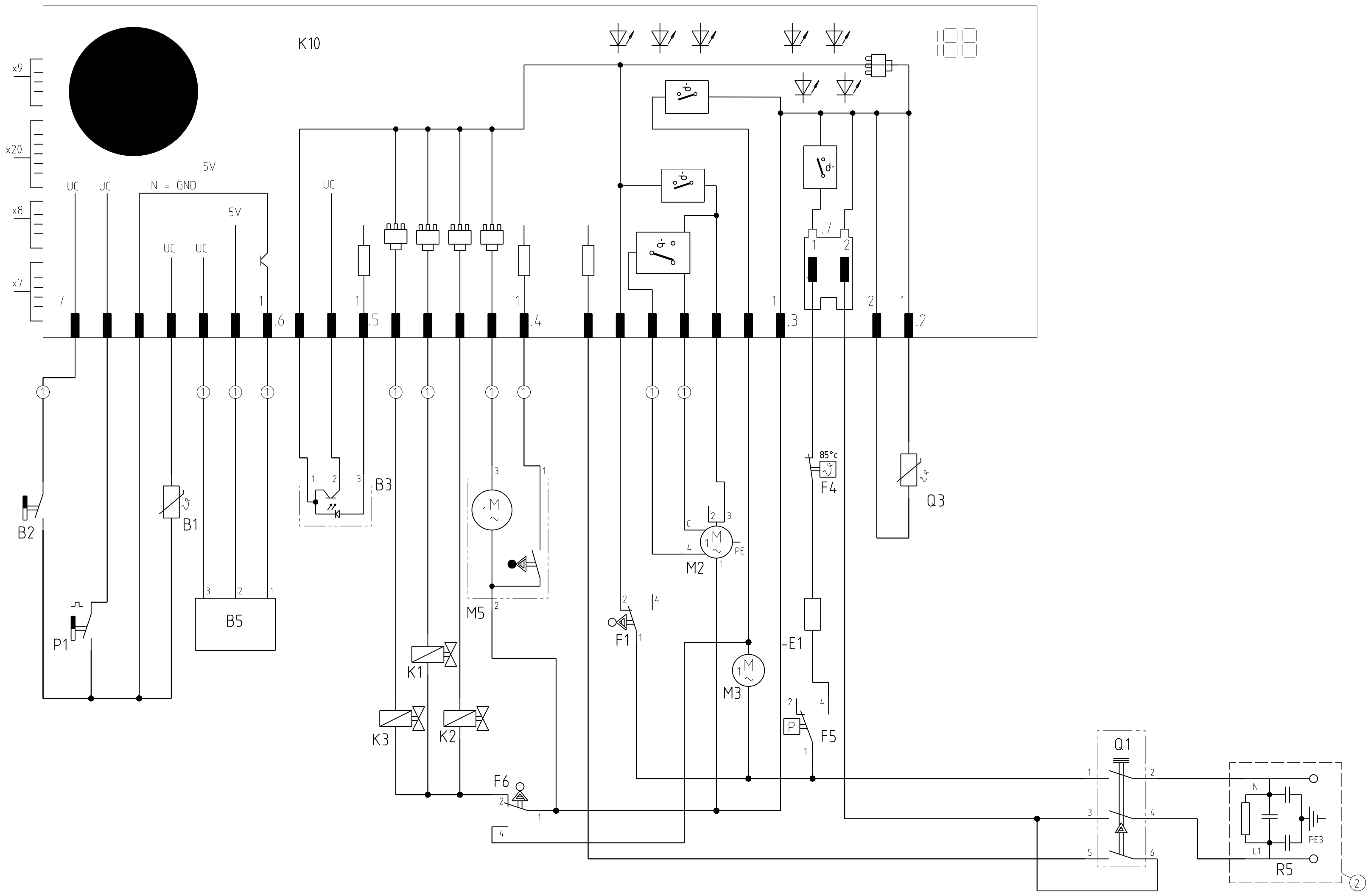

1 2 3 4 5 6 7 8 9 10 11 12 13 14 15 16 17 18 19 20 21 22 23 24 25 26 27 28 29 30 31 32 33 34 35 36 37 38 39 40 41 42 43 44 45 46 47 48 49 50 51 52 53

REF	Components	Path	REF	Components	Path
-E1	Heater	33	Q1	Main switch	42-44
B1	Temperature sensor NTC	13	Q3	Dispenser actuator	36
B2	Low salt sensor	9	R5	Mains connection with interference suppressor	47-49
B3	Low rinse aid sensor optical	18-19			
B5	Aqua sensor 1	14-16			
F1	Door switch	27-28			
F4	Safety thermostat	33			
F5	Safety pressure switch	33-34			
F6	Safety pressure switch	23-25			
K1	Regeneration valve	21			
K2	Filler valve	22			
K3	Drainage valve	20			
K10	Control unit	10-36			
M2	Circulation pump	29-31			
M3	Detergent solution pump	31			
M5	Water switch	23-25			
P1	Impeller meter	11			

- ① Fitted depending on features
- ② Mains connection without interference suppressor beginning FD8612