

main switch

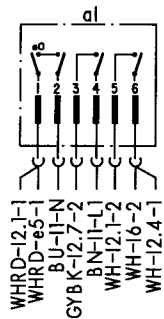

time delay, display and control modul

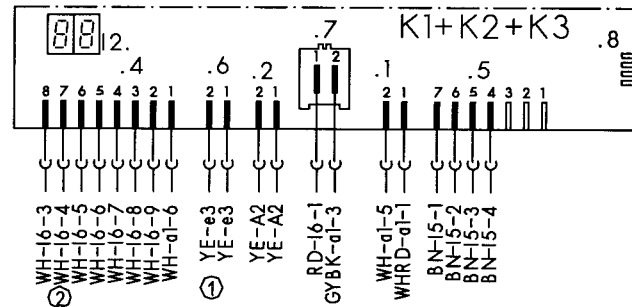

reed switch

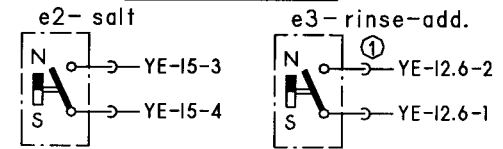

earth terminal

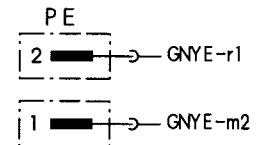

water points

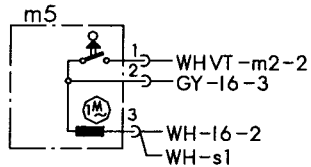

level switch

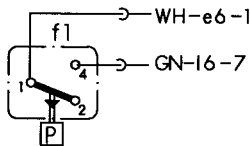

thermostat + NTC

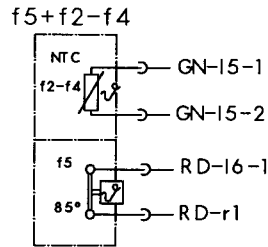

aktuator

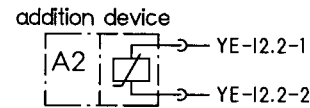

clutch

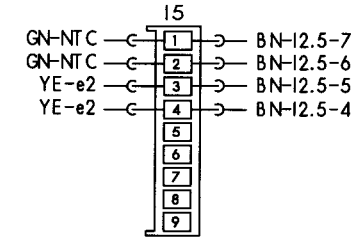

solenoid valves

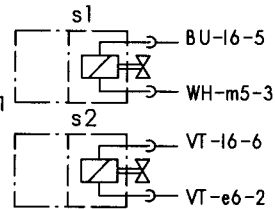

float switch

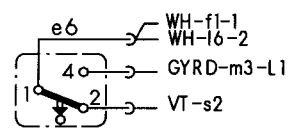

capacitor motor

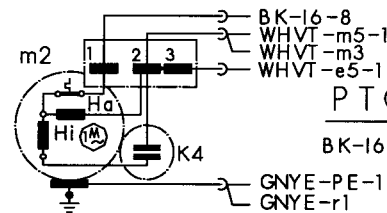

starter-PTC

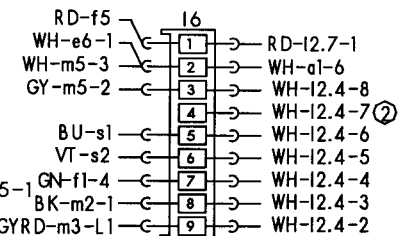
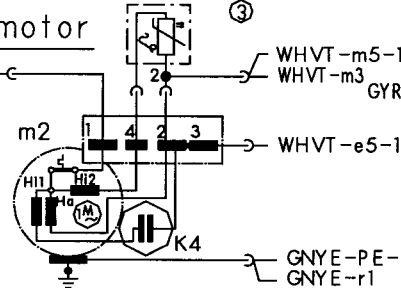

terminal I1 with interference suppression

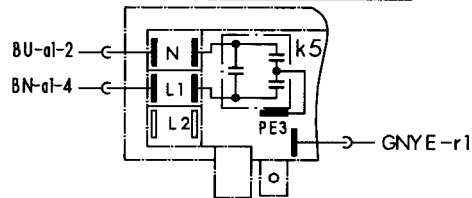

heating

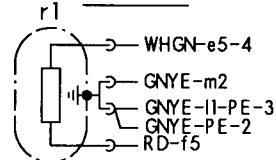

safety switch

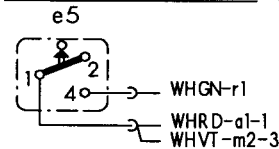

drain pump

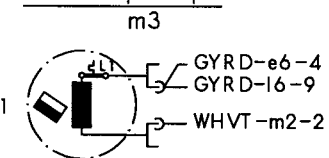

- ① exist according to equipment
- ② if exist without function
- ③ according to motortyp



Mat.Nr.: 5600044331	
Ausg.: 05.01	SO-60/ 0613

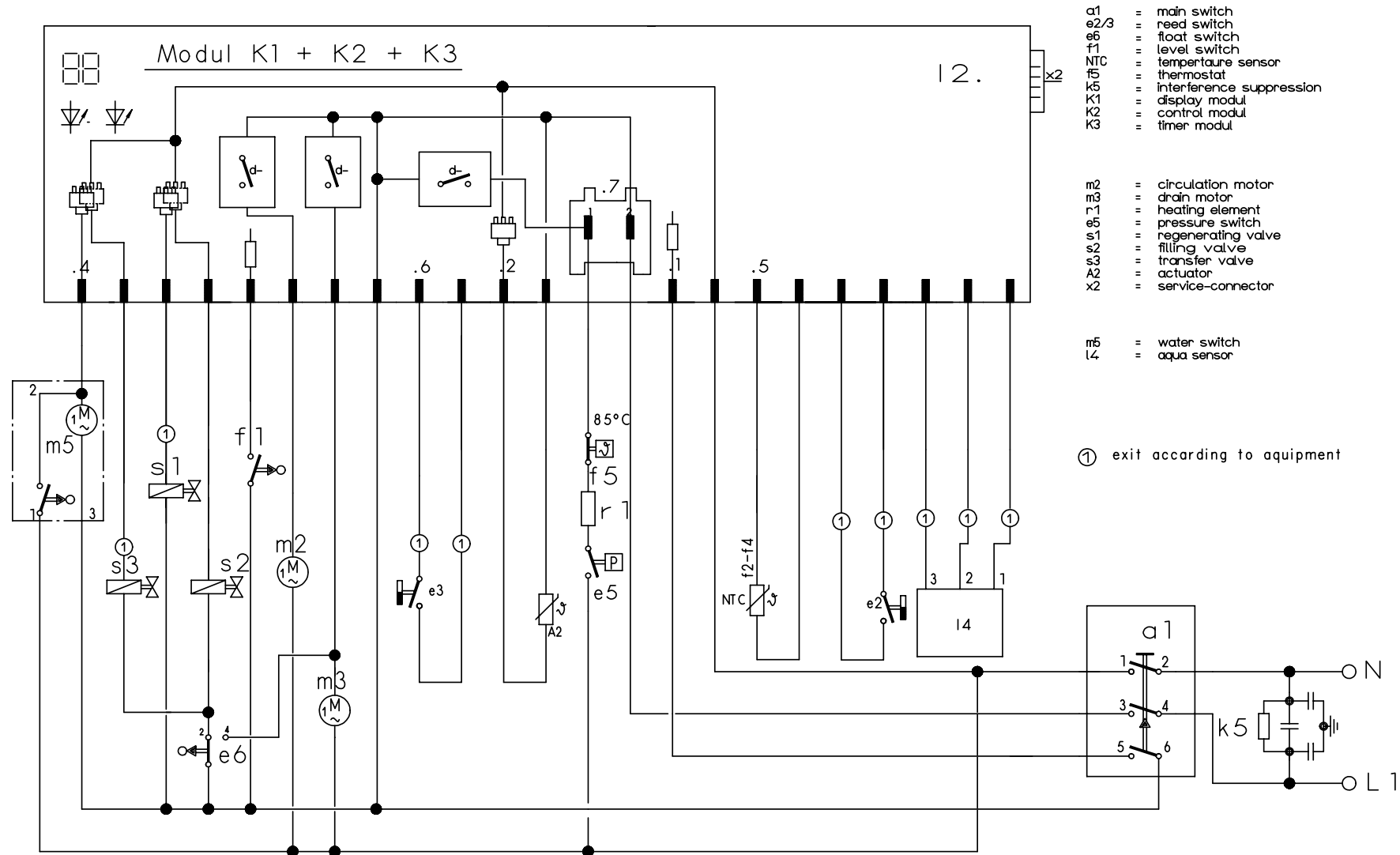

Mat. Nr. 5600042479	
Ausg.: 02.01	S0-60/0594



Customer service test programme

Function	Temperature	Capacity	Time (s)	Sensor	Abbreviations
1	P		15		P = Pump
2	VF			F1	VF = Prefill / static
3	F	3,4l* / 3.9l**			F = Fill / (level F1)
4	U + H + ZR	max. 72 °C	120		U = Circulate
5	U + H	60 °C			H = Heat
6	U + H + R	max. 72 °C	120		ZR = Dispenser detergent
7	U + H + ZK	max. 72 °C	120		ZK = Dispenser rinse-aid
8	P		60		R = Regenerate
9	FWW		60		FWW = Flush
10	P		30		

* = for 45 cm width, ** = for 60 cm width

To select the test programme press and hold the S2 and S4 buttons simultaneously and switch on the appliance.

The following displays are indicated on the control panel:

- LEDs L2 and L4 flash.
- As long as the two S2 and S4 buttons remain depressed after the dishwasher has been switched on, the model coding is displayed binary coded via L2, L3 and L4.
(e.g. L2 permanently on = Model 1, L2 + L3 permanently on = Model 3)
- By pressing one of the buttons, the associated LED lights up.
- By pressing the S3 button, the "low level" indicator LEDs and the End LED light up.

By pressing the S2 and S4 buttons, the test programme starts.

The test programme is ended by switching off the appliance via the main switch.

- The fault is displayed via LEDs:

L2 permanently on = Heater fault

L3 permanently on = Filling fault

L4 permanently on = NTC fault

L5 permanently on = Water switch cannot be positioned

(On appliances with 3 programmes it is only visible without panel frame !)

The next programme step can be selected by pressing the S3 button.

(Exception: Select the filling step with the F1 filling switch only)

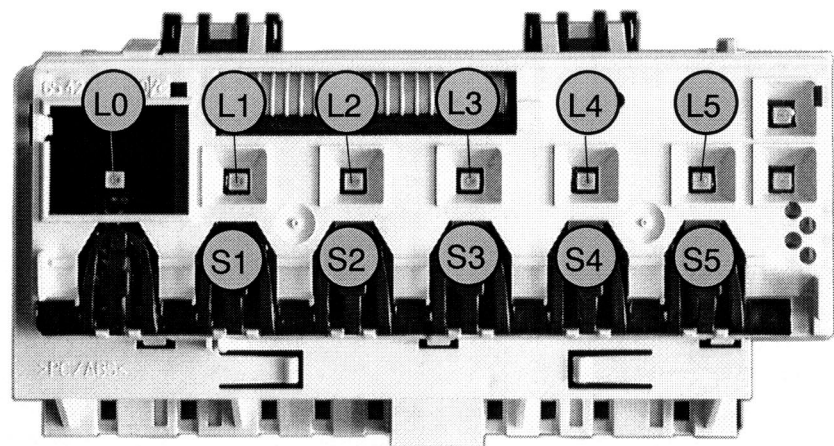

5600.045.158

Issued: 09.01

H_WE, WW;
GV450/630

S0-60/0607

Coding instructions

After replacing the electronic controls (standard installation), the control must be recoded with the appliance programmes (see table).

Note: In the case of appliances with 3 programmes/buttons the control must be programmed before the control panel frame is attached.

1. Selection:

Simultaneously press and hold down the S2, S3, S4 and S5 buttons and press the main switch. As long as the S2 to S5 buttons remain depressed, the L2 to L5 LEDs flash.

When the S2 to S5 buttons are released, the current coding is displayed binary coded via the L2, L3 and L4 LEDs (see code table).

2. Selecting the model:

The various codings can be selected by pressing the S2 button (see table).

3. Storing the coding:

The new coding is stored by switching off the appliance.

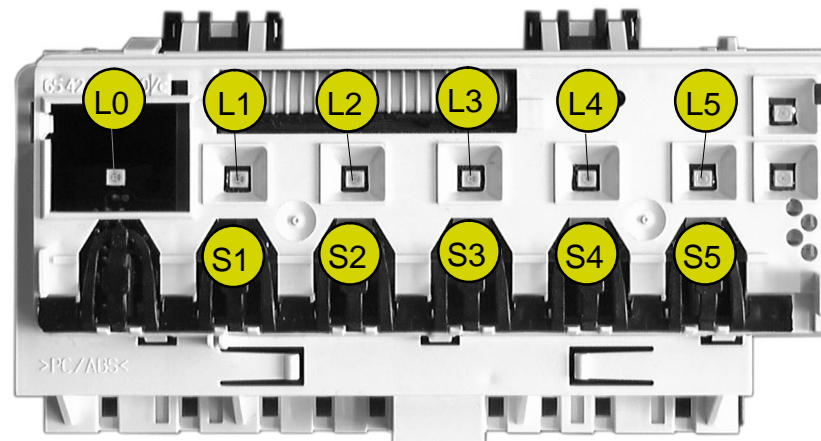

Code table:

Coding	Button					Display		
	S1	S2	S3	S4	S5	LED L2	LED L3	LED L4
0	---	---	---	---	---	○	○	○
1	---	Normal 65°	ECO 50°	Quick wash 35°	Pre-rinse	⊗	○	○
2	---	Normal 65°	ECO 50°	Vorspülen		○	⊗	○
3	Intensive 70°	Normal 65°	ECO 50°	Quick wash 35°	Pre-rinse	⊗	⊗	○
4						○	○	⊗

LED off ○

LED illuminates ⊗

Programme symbols:



Intensive 70°



Quick wash 35°



Normal 65°



Gentle 40°



ECO 50°



Pre-rinse



5600.045.163	Ausg.: 08.01
H_WW; GV450/630	S0-60/0608