

main switch

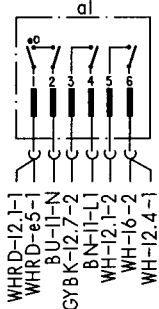

service and control module

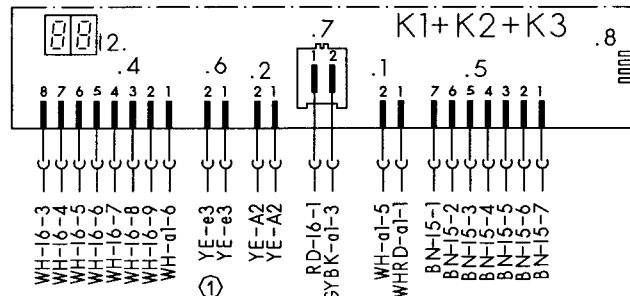

reed switch

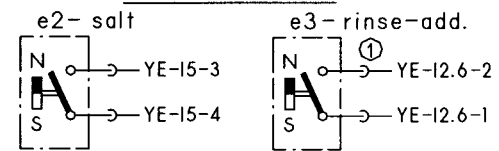

earth terminal

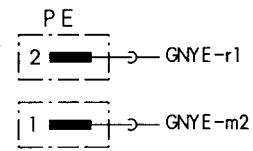

aqua-sensor



clutch

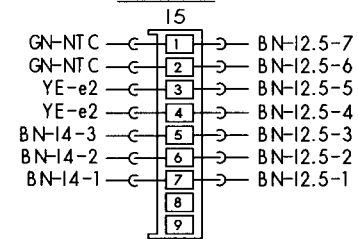

water points

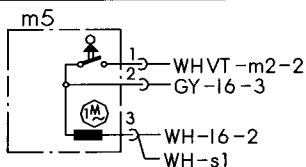

level switch

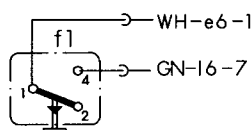

thermostat + NTC

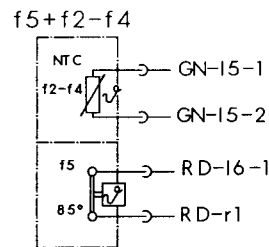

aktuator

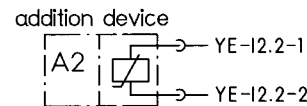

solenoid valves

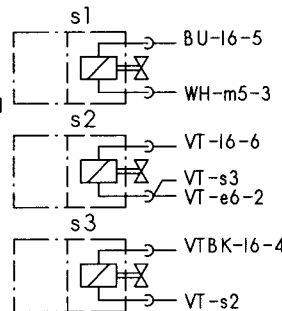

float switch

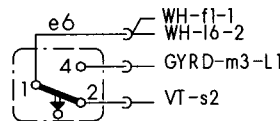

capacitor motor

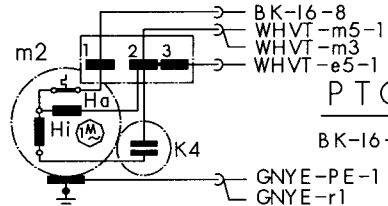

PTC-motor

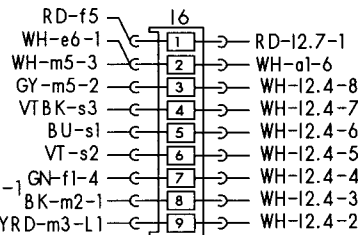
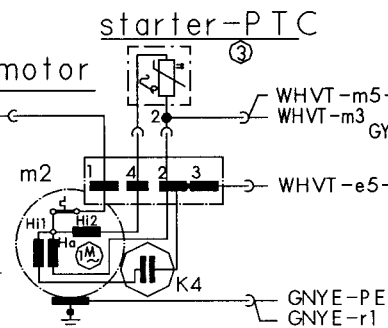

terminal I1 with interference suppression

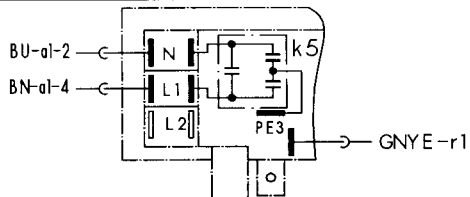

heating

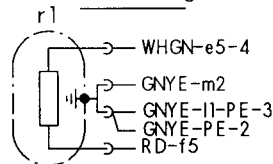

safety switch

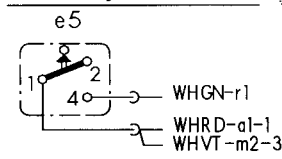

drain pump

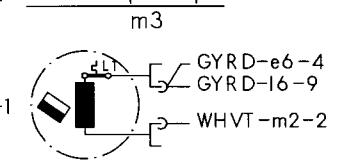

① exist according to equipment

③ according to motortyp



Mat.Nr.: 5600042480	
Ausg.: 03.01	SO-60/ 0600

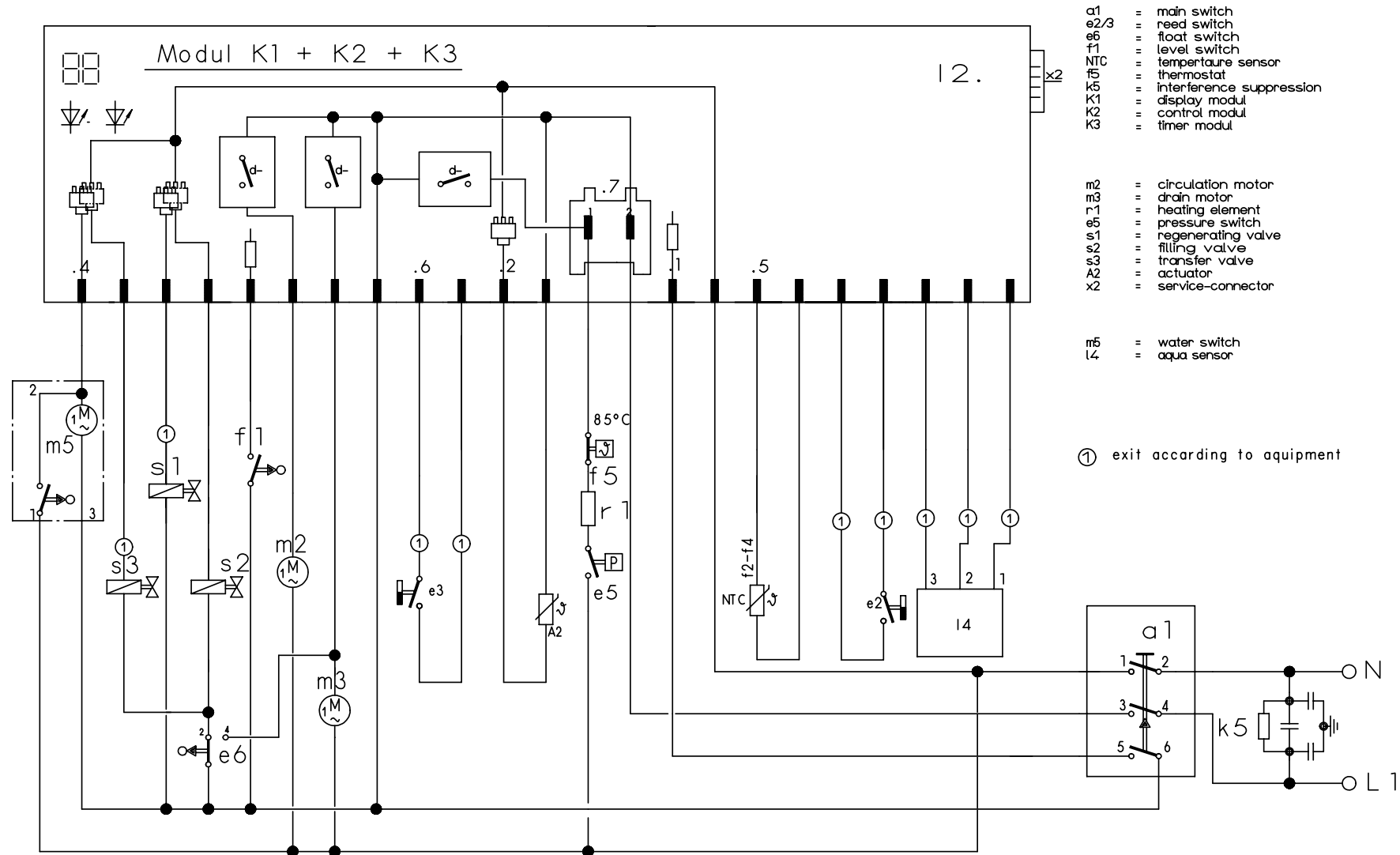

Mat. Nr. 5600042479	
Ausg.: 02.01	S0-60/0594



Coding instructions

After replacing the electronic controls (standard installation), the control must be recoded with the appliance programmes (see table).

Note: In the case of appliances with 3 or 4 programmes/buttons the control must be programmed before the control panel frame is attached.

1. Selection:

Simultaneously press and hold down the S2, S3, S4 and S5 buttons and press the main switch. As long as the S2 to S5 buttons remain depressed, the L2 to L5 LEDs flash.

When the S2 to S5 buttons are released, the current coding is displayed (see code table).

2. Selecting the model:

The various codings can be selected by pressing the S2 button (see table).

3. Storing the coding:



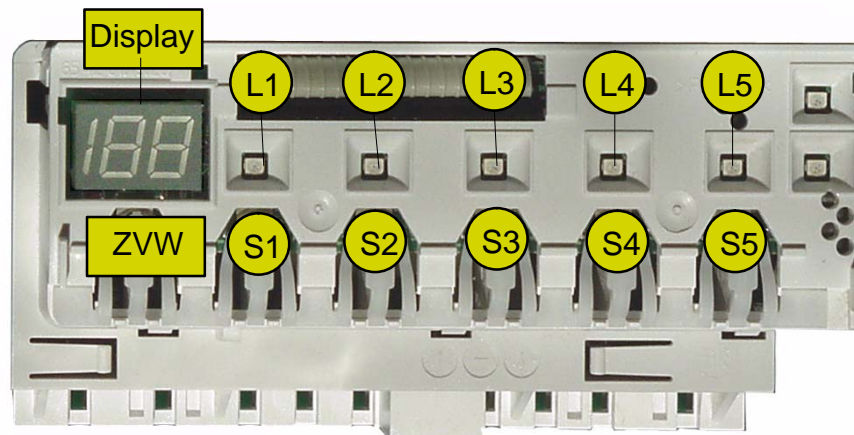



The new coding is stored by switching off the appliance.



Code table:

S0	S1	S2	S3	S4	S5	Display
ZVW	auto 55/65° Normal 65°	ECO 50°	Quick wash 35°	Pre-rinse		26
ZVW	Intensive 70°	auto 55/65°	ECO 50°	Quick wash 35°	Pre-rinse	27
ZVW	OK	auto 55/65°	ECO 50°	Quick wash 35°	Pre-rinse	28
ZVW	auto 55/65°	ECO 50°	Gentle 40°	Quick wash 35°		29

Programm-Symbole:

	Intensive 70°		Quick wash 35°		Upper rack washing (OK)
	auto 55/65°		Gentle 40°		Time preselection (ZVW)
	ECO 50°		Pre-rinse		



5600 044 492	Issued: 07.02
G; WE; WW; GV630/450	S0-60/0596

Customer service test programme

Function	Temperature	Rinsing Technology	Capacity	Time (s)	Sensor	Abbreviations
1	P			15		P = Pump
2	VF				F1	VF = Prefill
3	F		3,4 l* / 3,9 l**			F = Fill
4	U + H + ZR	max 72°C	WS	120		U = Circulate
5	U + H	60°C	WS			H = Heat
6	U + H + R	max.72°C	WS	120		ZR = Detergent dispenser
7	U + H + ZK	max.72°C	WS	120		ZK = Rinse-aid dispenser
8	AS_KAL_IR					R = Regenerate
9	P			60		FWW = Flush
10	FWW + AWT			60		AS_KAL_IR = Calibration of turbidity sensor
11	P + AWT			30		AWT = Outlet

* = for 45 cm width, ** = for 60 cm width

Call up:

- Switch off the appliance
- Press the buttons S2 and S4 and keep them pressed
- Switch on the mains switch.

The following displays are indicated on the control panel:

- LEDs L2 and L4 flash.
- As long as the two S2 and S4 buttons remain depressed after the dishwasher has been switched on, an identifier for the model coding is displayed when the overtravel contact has been successfully interrogated.
- By pressing one of the buttons, the associated LED lights up.
- By pressing S3 button, the display shows "188", the SALT, Rinse aid and prog. LED's are lit.
- By pressing the timer programming button, an 18h on the segment display light up.

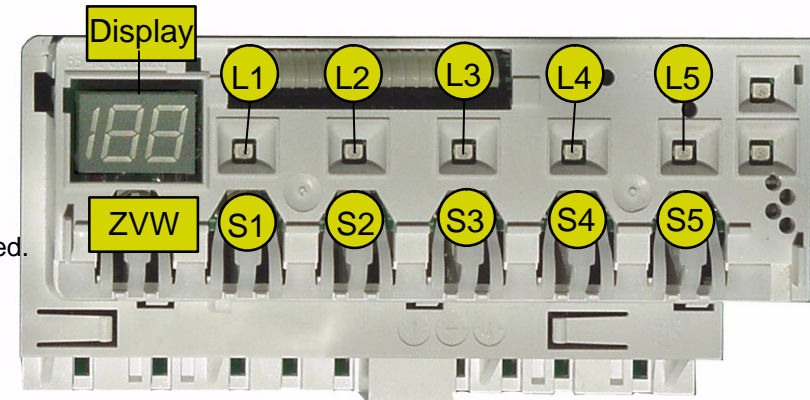

Programme start:

- Press the buttons S2 and S4 again.

If the button S1 is pressed during the change-over-rinsing (WS), the water switch remains in the upper basket position at the following change (within 60 s). The LED L1 shines as long as the upper basket function is selected. A timer programming is not possible. The test programme is stopped by switching off the appliance with the main switch.

The potential fault code is displayed.

Fault code	
0	There is no fault
1	Fault in the hydro sensor system Note: Display even if there is no sensor!
2	Heater fault
4	Filling fault
8	Fault in NTC system
16	Water switch cannot be positioned

If more than one fault is detected, the fault code is added up. (f.ex.: fault code 3 = fault 1 + fault 2)

The next programme step can be selected by pressing the S3 button; (Exception: Select the filling step with the F1 filling switch only).



5600 041 848	Issued: 10.01
G; WT; WW; GV630	S0-60/0601