

on-off and selector switch

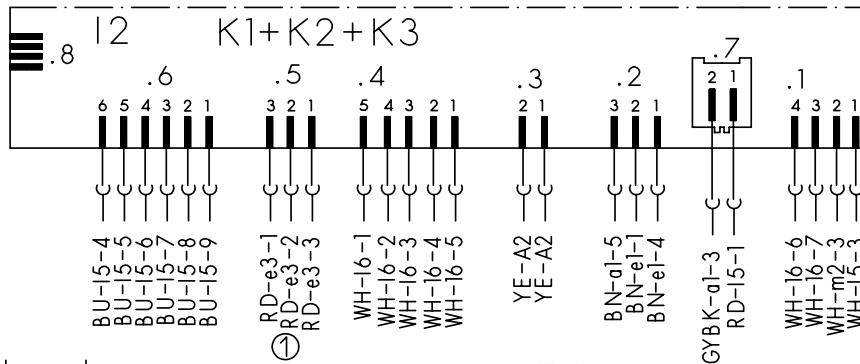

sensor

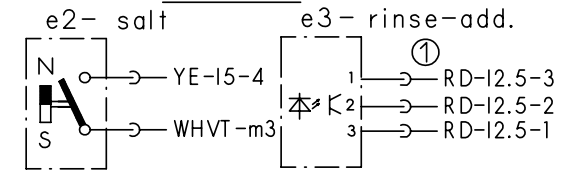

main switch

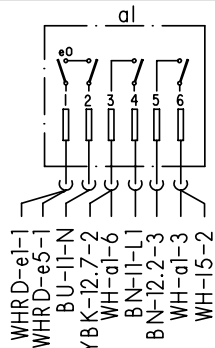

aqua-sensor

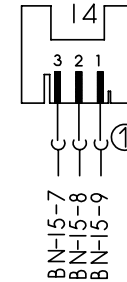

earth terminal

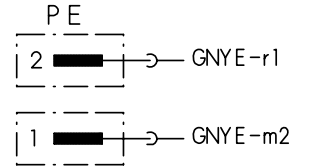

solenoid valves thermostat + NTC

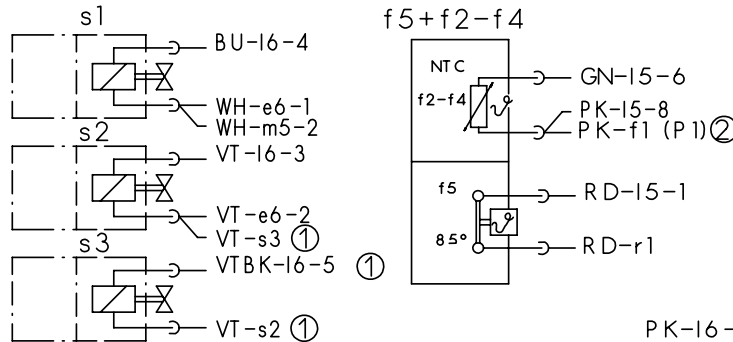

aktuator

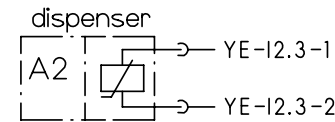

water points

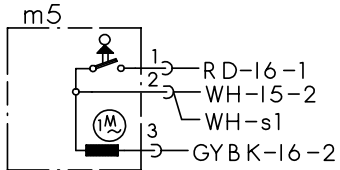

clutch

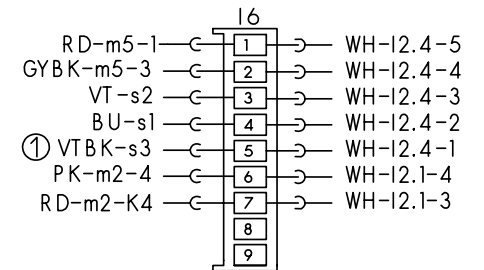

float switch

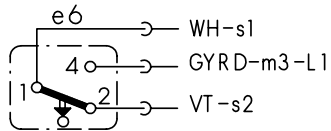

level switch

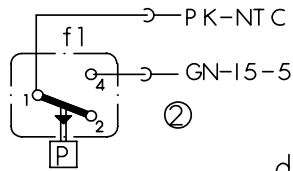

motor

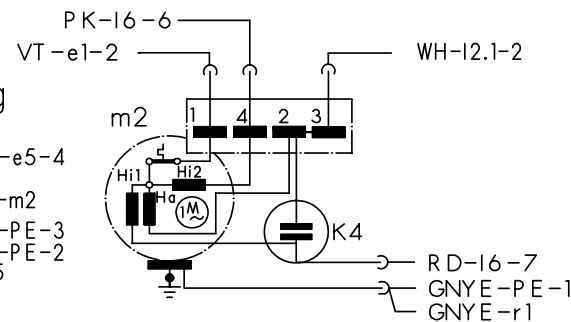

heating

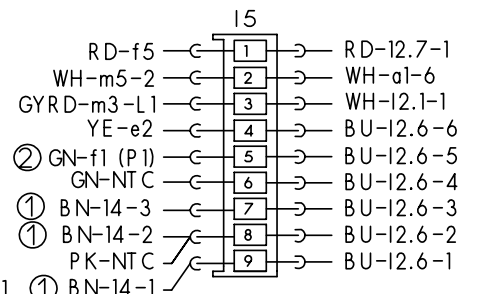
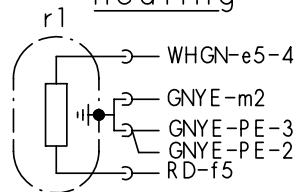

terminal I1 with interference suppression

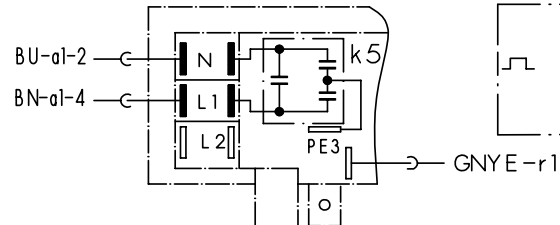

flowmeter

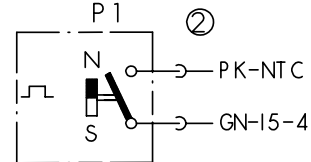

door switch

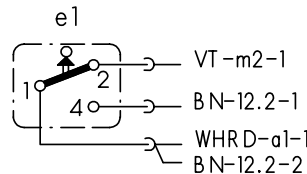

safety switch

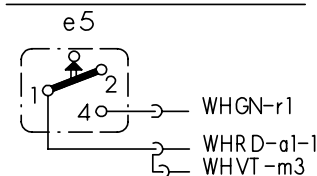

drain pump

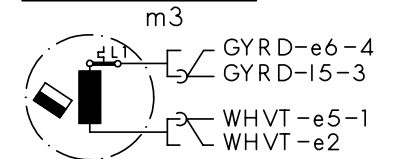

- ① exist according to equipment
- (.) previous color
- ② exist according to version



Mat.Nr.: 9000017140	
Ausg.: 04.04	S0-60/0894

The reproduction, transmission or use of this document or its contents is not permitted without express written authority. Offenders will be liable for damages. All rights including rights created by patent, grant or registration of a utility model or design are reserved. Copyright reserved.

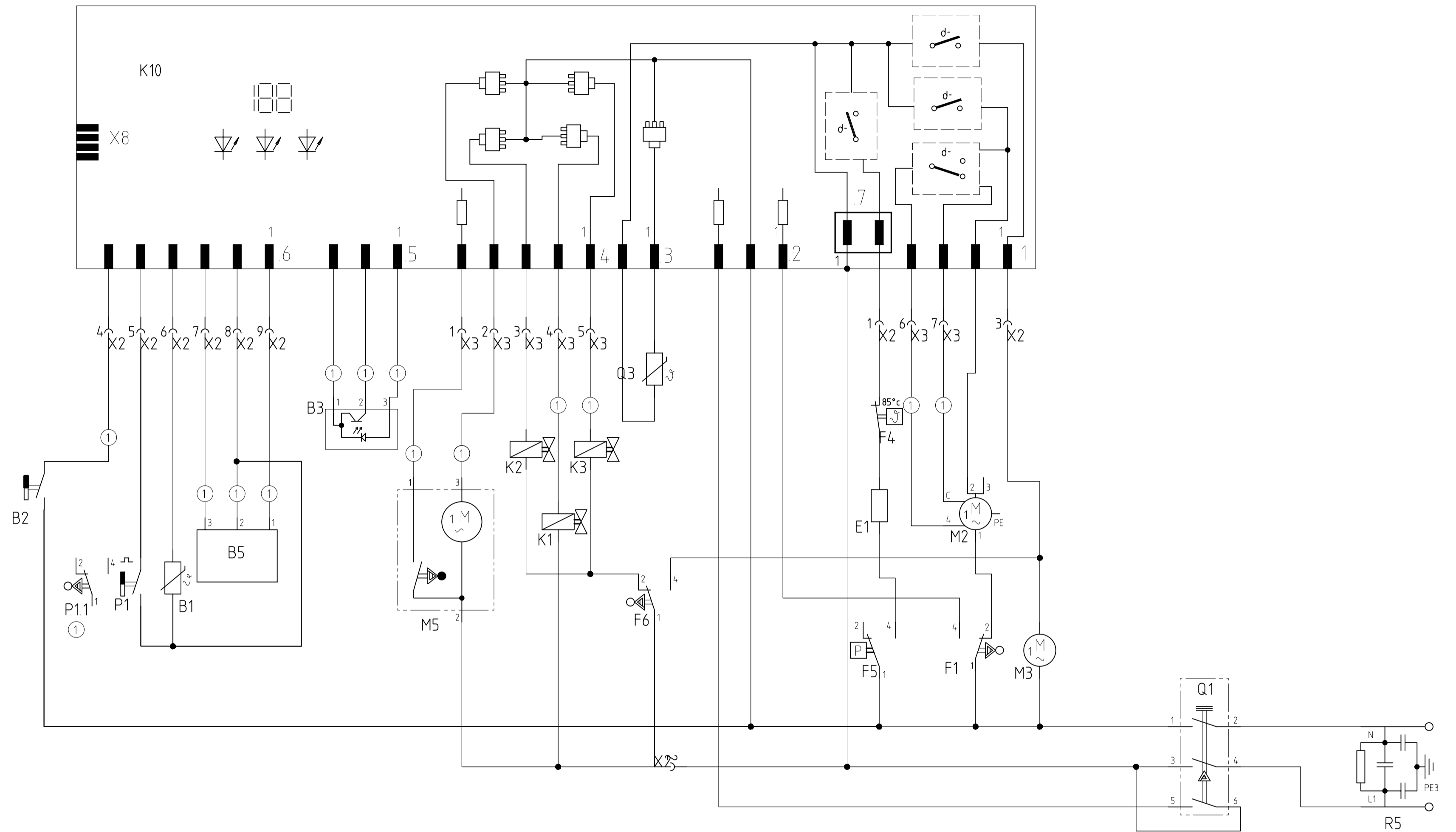

REF	Components	Path	REF	Components	Path	REF	Components	Path
B1	Temperature sensor ntc	15	F6	safety pressure switch	29-31	P11	Level switch	12,13
B2	Low salt sensor	11	K1	Regeneration valve	27	Q1	Main switch	46,48
B3	Low rinse aid sensor optical	20-22	K2	Filler valve	26	Q3	Dispenser actuator	30
B5	Aqua sensor 1	16-18	K3	Drainage valve	28	R5	Mains connection with interference suppressor	52,54
E1	Heater	37	K10	Control unit	13-18,20-22,24-30,32-34,36-41			
E1	Heater		M2	Circulation pump sicasym	39-41			
F1	Door switch	39,40	M3	Detergent solution pump	42			
F4	Safety thermostat	37	M5	Water switch	22,24			
F5	Safety pressure switch	36,37	P1	Impeller meter	14			

① Fitted depending on features

# Customer service test programme

## 1. Selecting the model coding:

- Switch off the appliance.
- When the door is closed, hold down two buttons and press main switch until the model coding is indicated via the LEDs L2 – L4.

## 2. Selecting the special programme:

- When the two buttons are released, LED L3 lights up and LED L4 flashes.

## 3. Reading out the fault memory:

- Press button S4 to read out the fault memory of the last wash cycle.
- A fault which has occurred is indicated via LEDs L2 – L4 (see Fault code table). If a fault has not occurred in the last wash cycle, LED L3 remains lit and LED 4 continues flashing.

## 4. Customer service test programme

- When the fault memory has been read out, press button S3. The customer service programme starts.
- While the programme is running, LED L4 flashes.
- A fault which has occurred is indicated immediately as a code via LEDs L2 – L4 (heating fault after 60 minutes).
- If several faults occur, only the fault with the highest value is displayed.
- While the customer service programme is running, each status change of the analogue signal inputs (e.g. filling switch F1) is acknowledged by the electronics module with LEDs which flash briefly. (Performance test of the LEDs)
- The water points are actuated for as long as the programme is running.
- Following each repair a customer service test programme must be run to detect any other faults.
- Switch to the next programme position with the S3 button. (Exception: Move to the next filling step by pressing filling switch F1 only).

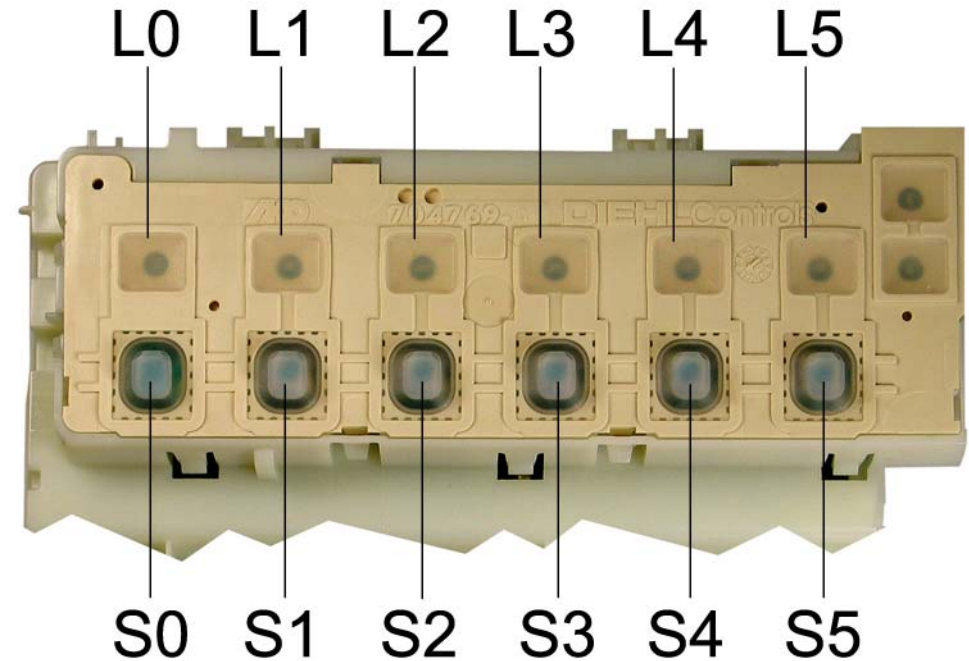

Document No. 58300000108139 ASP EN A	Rev. A	Sheet-No. 1 of 2
Material No. 9000 032 729	GV630 , H rati , WE, DS	

### Fault code table:

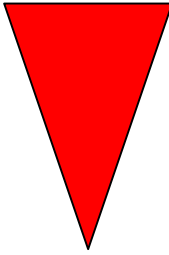
Fault code without display			Fault type	Value
L1	L2	L3		
○	○	✱	Heating fault	
○	✱	○	NTC fault	
○	✱	✱	Filling fault	
✱	○	○	Water points cannot be positioned	
✱	○	✱	- - -	
✱	✱	○	Aqua sensor	
✱	✱	✱	- - -	

○ = LED off      ✱ = LED flashes quickly (2 Hz)

### Sequence of the customer service test programme:

	Function	Temperature	Capacity	Time (s)	Sensor	Symbol
1	P			15		P = Pump
2	VF		1.5 l			VF = Prefill
3	PA			5		F = Fill (level F1)
4	F + reversal relay/auxiliary winding (SICASYM)		2.4 l	X + 10		U = Circulate
5	U + H + ZR	max. 72 °		120		H = Heat
6	U + H	60 °C				ZR = Dispense detergent
7	U + H + R	max. 72 °		120		ZK = Dispense rinse aid
8	U + H + ZK	max. 72 °		120		R = Regeneration valve
9	WP			30		FWW = Fill soft water
10	P			45		WP = Alternating pump
11	FWW			60		SP = Intermittent pump
12	SP			30		PA = Pause
13	P			30		X = Calculated refill time

Document No. 58300000108139 ASP EN A	Rev. A	Sheet-No. 2 of 2
Material No. 9000 032 729	GV630 , H rati , WE, DS	