

**Control unit**

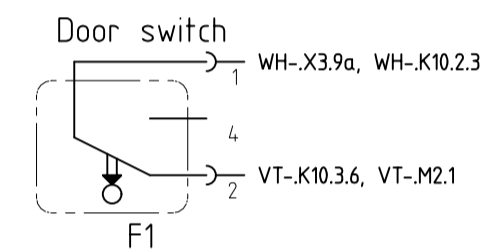

① RD-K10.6.3, RD-P2.2, RD-B3.1, SP1

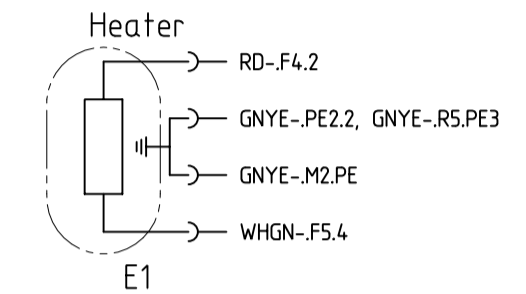
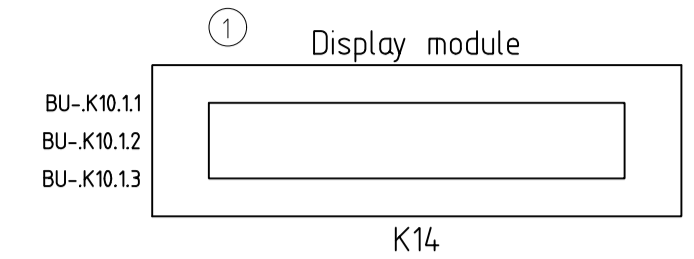
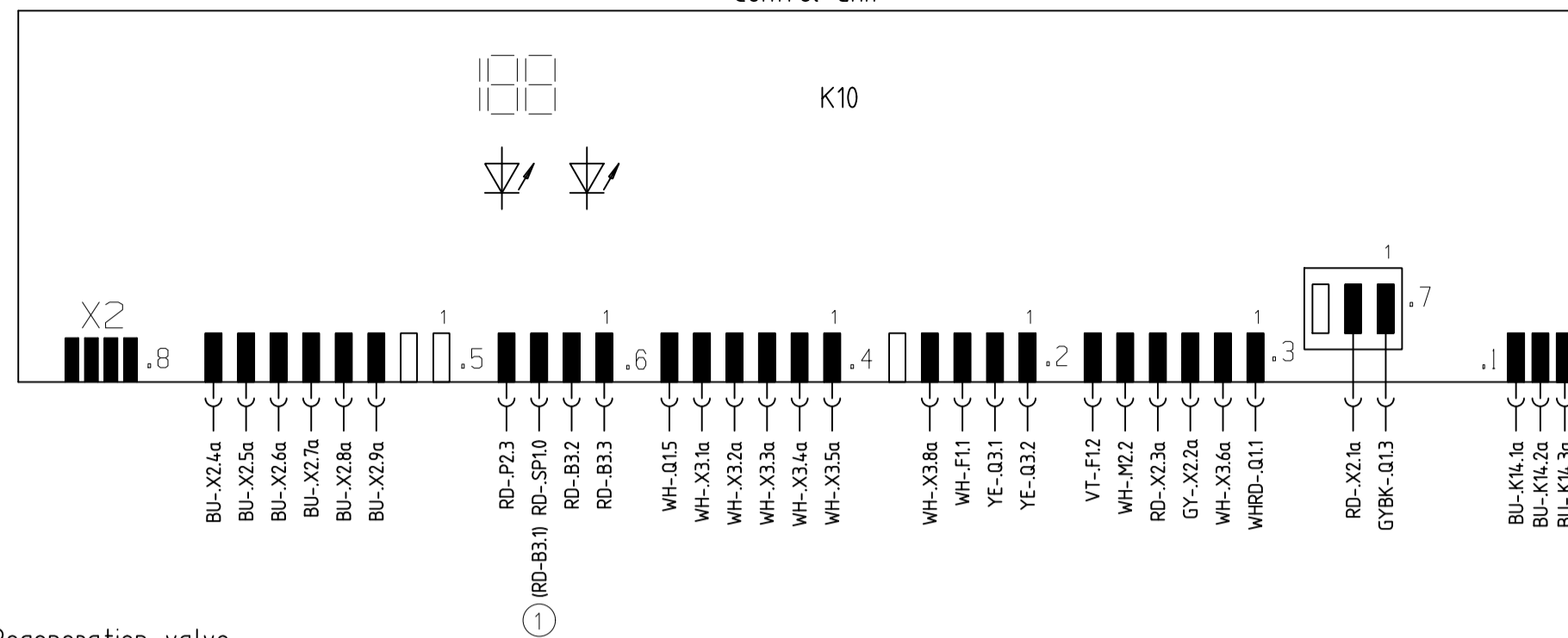
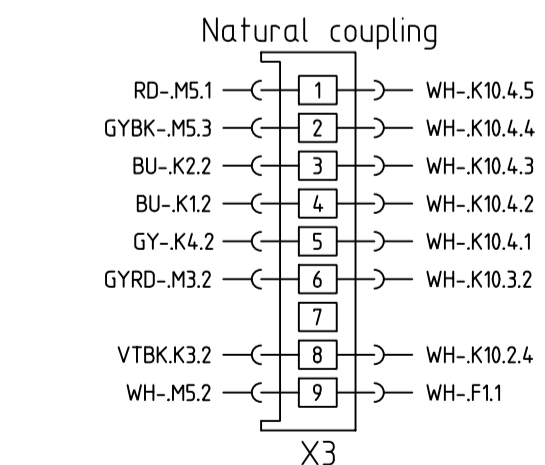
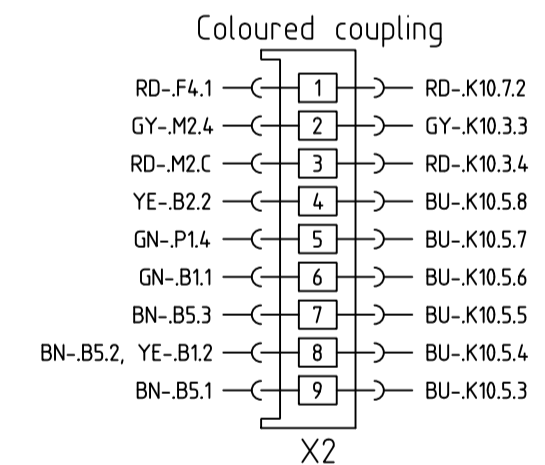
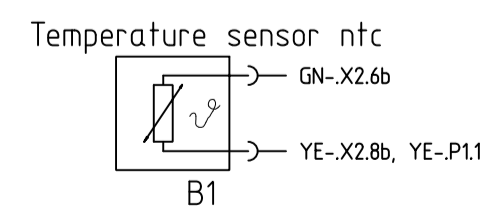
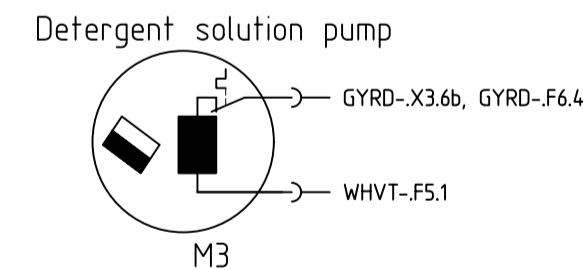
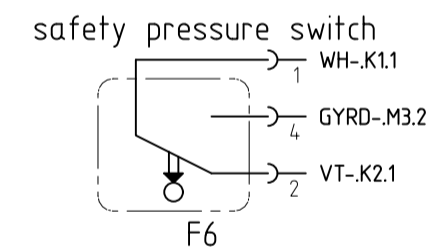
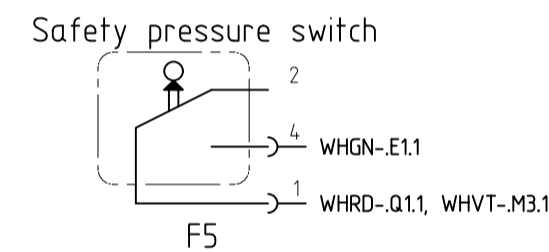
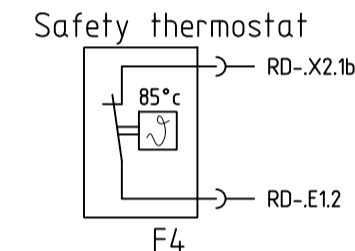

① Fitted depending on features

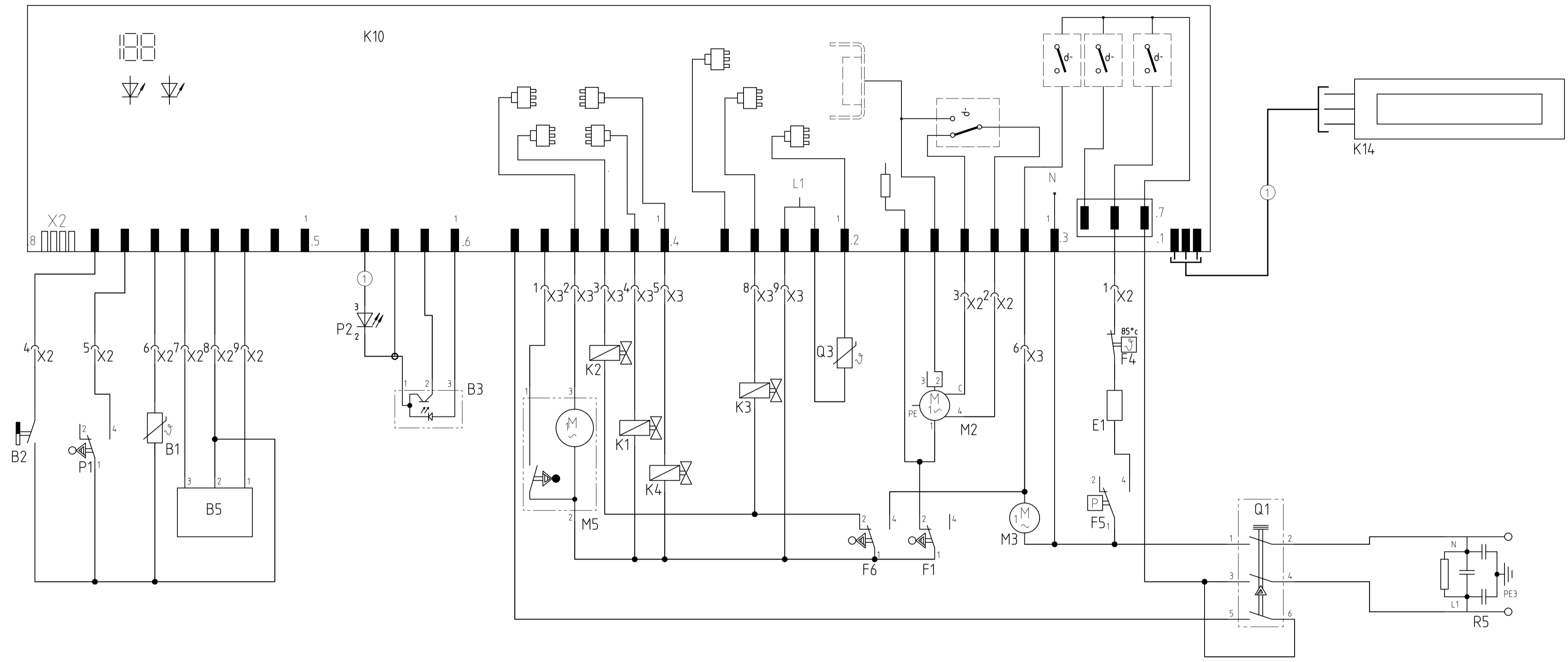

1 2 3 4 5 6 7 8 9 10 11 12 13 14 15 16 17 18 19 20 21 22 23 24 25 26 27 28 29 30 31 32 33 34 35 36 37 38 39 40 41 42 43 44 45 46 47 48 49 50 51 52 53 54 55

REF	Components	Path	REF	Components	Path
B1	Temperature sensor ntc	7	M3	Detergent solution pump	36
B2	Low salt sensor	3	M5	Water switch	20,21
B3	Low rinse aid sensor optical	15-17	P1	Level switch	5,6
B5	Aqua sensor 1	8-10	P2	On light	14
E1	Heater	39	Q1	Main switch	43,45
F1	Door switch	32,33	Q3	Dispenser actuator	30
F4	Safety thermostat	39	R5	Mains connection with interference suppressor	50,52
F5	Safety pressure switch	38,39			
F6	safety pressure switch	31,32			
K1	Regeneration valve	23			
K2	Filler valve	22			
K3	Drainage valve	27			
K4	Raw water valve	24			
K10	Control unit	10-42			
K14	Display module	47,54			
M2	Circulation pump	32-34			

(1) exist according to equipment

The reproduction, transmission or use of this document or its contents is not permitted without express written authority. Offenders will be liable for damages. All rights including rights created by patent grant or registration of a utility model or design are reserved. Copyright reserved.

Designation Circuit Diagram GV 638 V+ Sicasym	LCS EN 5600 0000121271 Material No. 9000076603	Rev A	Sheet-No. 1 of 1
---	--	----------	------------------------

To Request

# Customer service test programme

## 1. Selecting the model coding:

When the door is open, hold down any two buttons and press main switch until the model coding is indicated on the display.

## 2. Select special programme:

When the two buttons are released, LED L3 lights up and LED L4 flashes P0 is displayed. The required special programme can be selected by pressing the S3 button.

- **P0** = Read out fault memory
- **P1** = Customer service test programme
- **P2/P3** = In-plant test programmes
- **P4** = Model coding

**Press S4 to acknowledge the selected programme**

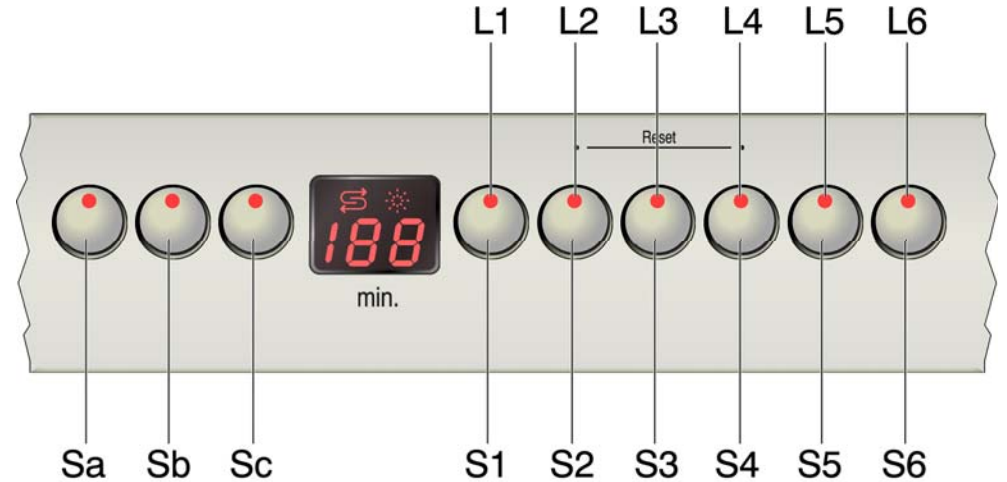

## 3. Read out fault memory (P0)

The faults of the last 8 wash cycles can be scanned by pressing the S4 button. When the button is pressed, the wash cycle is displayed (00–07). When the button is released, the associated fault is displayed (see table). If several faults occur in a wash cycle, only the fault with the highest value is displayed.

## 4. Customer service test programme (P1)

The customer service programme is started by closing the door.

Switch to the next programme position with the S3 button.

(Exception: Move to the next filling step by pressing filling switch F1 only).

Each status change of the processor inputs is acknowledged by all LEDs lighting up briefly.

A fault which has occurred is indicated immediately via the display (heating fault after 60 minutes). If several faults occur, only the fault with the highest value is displayed. Following each repair a customer service test programme must be run to detect any other faults.

Document No. 56000000111007 ASP EN A	Rev. A	Sheet-No. 1 of 2
Material No. 5600 059 979	GV638 ,V+ , WT, Sicasym	

## 5. Fault code:

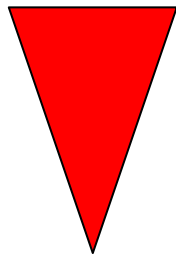
Fault code	Fault type	Value
E1	Heating fault	
E2	NTC fault	
E3	Filling fault	
E4	Water points cannot be positioned	
E5	- - -	
E6	Aqua sensor	
E7	- - -	

## 6. Sequence of the customer service test programme:

	Function	Temperature	Capacity	Time (s)	Sensor	Rinsing kind	Symbol
1	P			15			P = Pump
2	VF				VF		VF = Prefill
3	PA			5			F = Fill (level F1)
4	F		3.9				U = Circulate
5	U + H + ZR	max. 72°		120		WS with OK reduced	H = Heating
6	U + H	60°				OK	ZR = Dispense detergent
7	U + H + R	max. 72°		120		WS	ZK = Dispense rinse aid
8	U + ZK			120		WS	R = Regeneration valve
9	AS_KAL_IR						FWW = Fill soft water
10	WP			30			AS_KAL = Calibrate Aqua sensor
11	P			45			AWT = Heat exchanger outlet valve
12	FWW + AWT			60			WP = Alternating pump
13	SP			30			SP = Intermittent pump
14	P + AWT			30			WS = Alternate washing
							OK = Top basket

Document No. 56000000111007 ASP EN A	Rev. A	Sheet-No. 2 of 2
Material No. 5600 059 979	GV638 ,V+ , WT, Sicasym	