

- a1 = Hauptschalter
- e1 = Tuerschalter
- e2/3 = Reedschalter Satz/Klarsp.
- e6 = Schwimmerschalter
- P1 = Fluegelradzaehler
- NTC = Temperatursensor
- f5 = Temperaturregler
- k5 = Entstoerung
- K1 = Anzeige - u. Bedienmodul
- K2 = Steuerungsmodul
- K3 = Zeitvorwahl
- m2 = Umwaelpumpe
- m3 = Pumpe entleeren
- r1 = Heizung
- e5 = Druckschalter
- s1 = Regenerierventil
- s2 = Fuellventil
- s3 = Auslassventil
- A2 = Zugabe-Aktuator
- x2 = Service-Anschluss
- m5 = Wasserweiche
- l4 = Aqua-Sensor
- s4 = Rohwasserventil

① je nach Ausstattung
 ② je nach Ausfuehrung

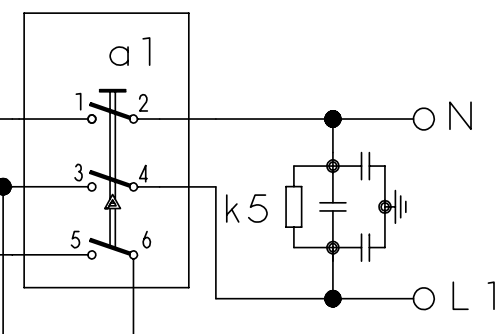

Mat. Nr. 5600060772	
Ausg.: 09.03	56000000109148



Bedien- u. Steuermodul

Anzeigemodul

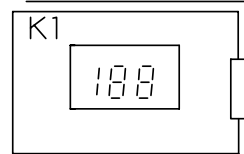

Hauptschalter

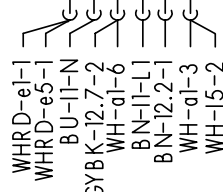
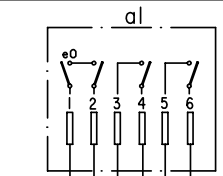

Wasserweiche

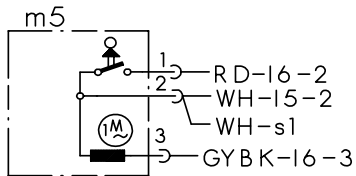

Schwimmersch.

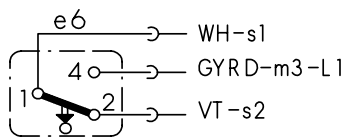

Niveaudruckdose

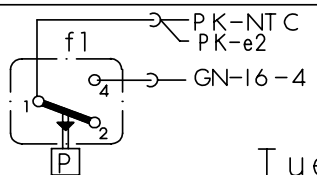

Tuerschalter

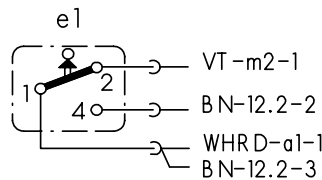

Sicherheitssch.

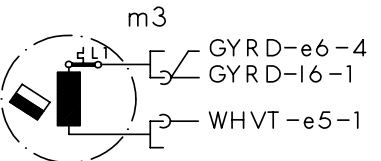
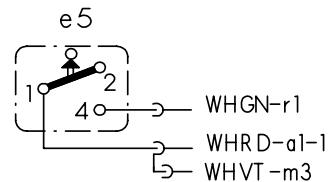

Mat.Nr.:	9000006175
Ausg.:	01.04
	56000000111029

① je nach Ausstattung vorhanden
(.) Farbenwechsel



Sensoren

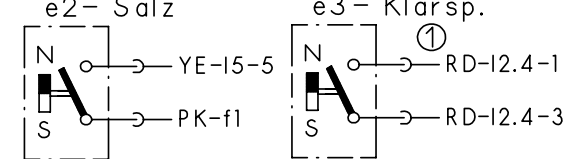

Aqua-Sensor

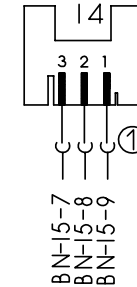

Schutzleiter

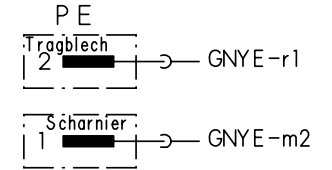

Kupplung

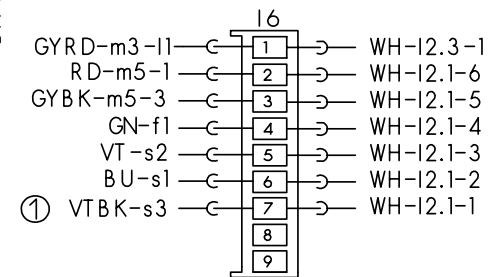

Aktuator

Zugabevorrichtung

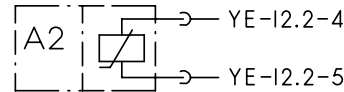

Motor

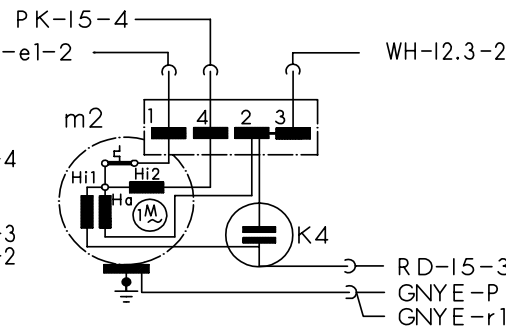

Heizung

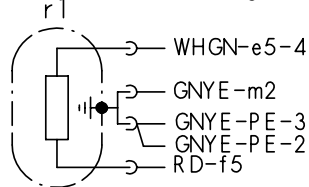

Magnetventile

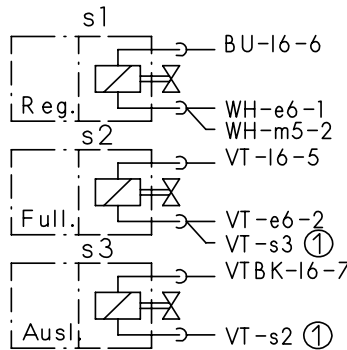

Temperaturregler + NTC

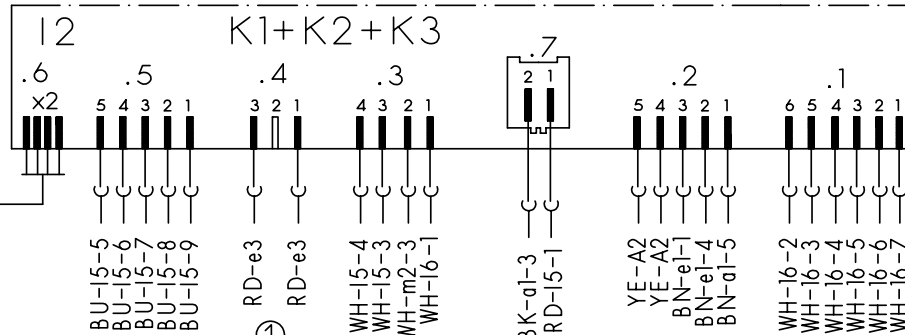
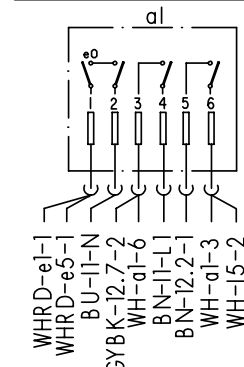
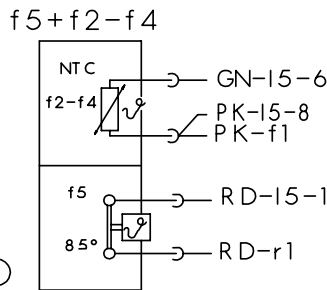

Aqua-Sensor

Schutzleiter

Kupplung

Aktuator

Zugabevorrichtung

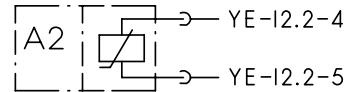

Motor

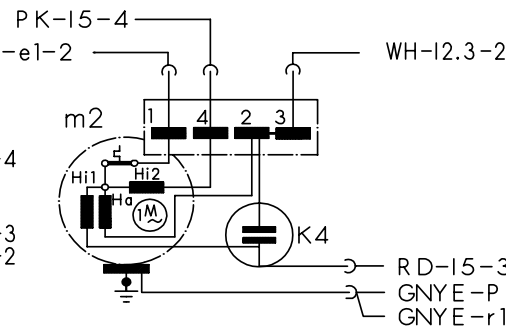

Heizung

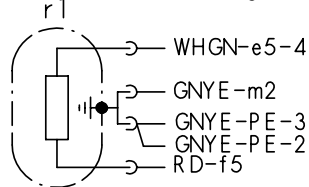

Magnetventile

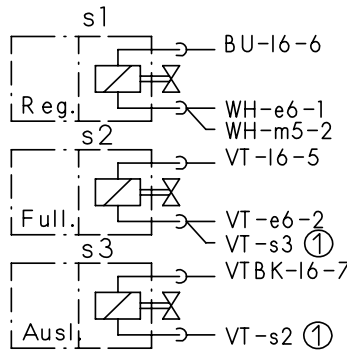

Temperaturregler + NTC

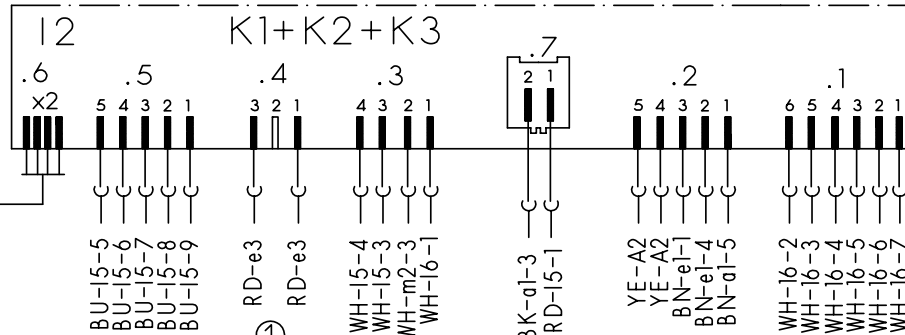
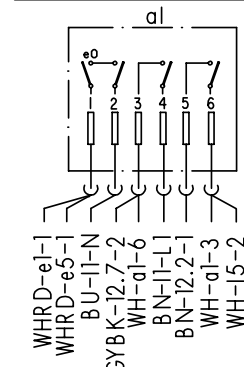
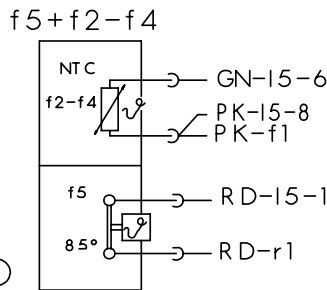

Aqua-Sensor

Schutzleiter

Kupplung

Aktuator

Zugabevorrichtung

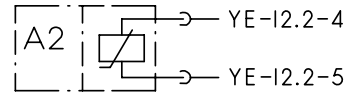

Motor

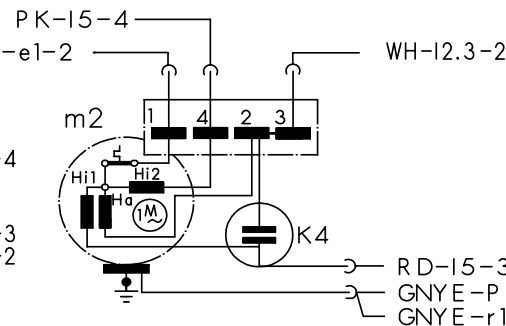

Heizung

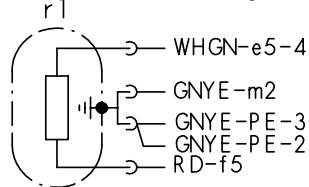

Magnetventile

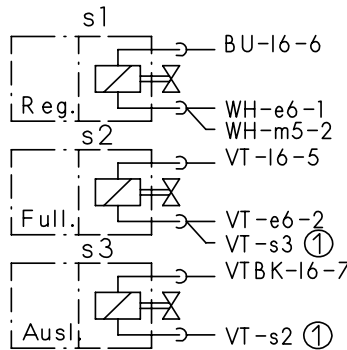

Temperaturregler + NTC

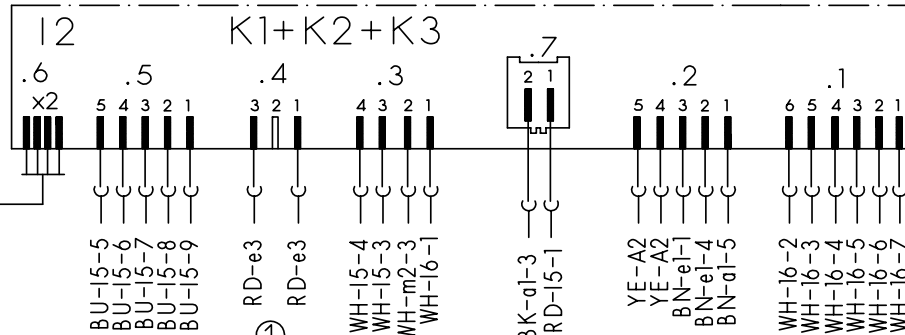
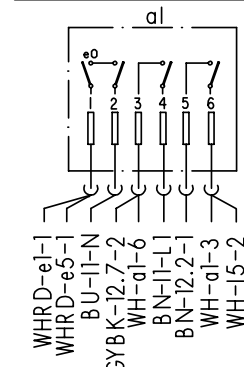
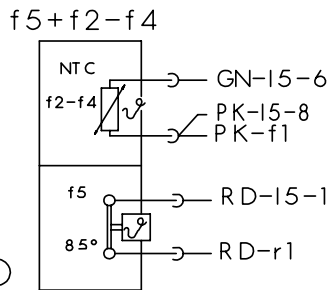

Aqua-Sensor

Schutzleiter

Kupplung

Aktuator

Zugabevorrichtung

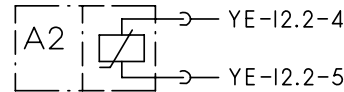

Motor

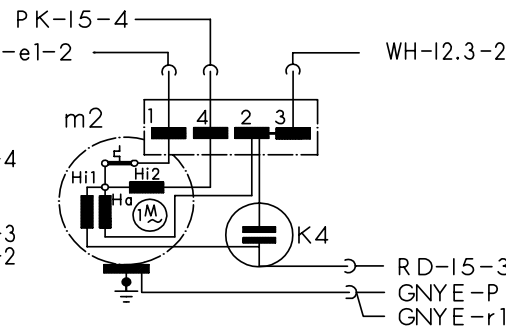

Heizung

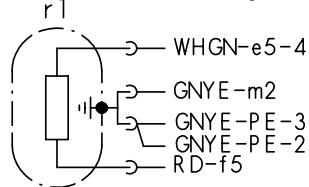

Magnetventile

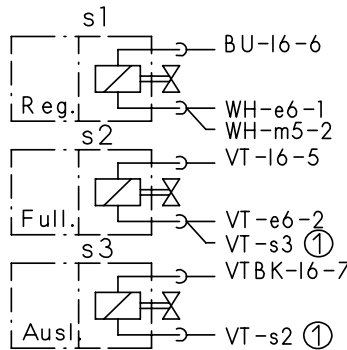

Temperaturregler + NTC

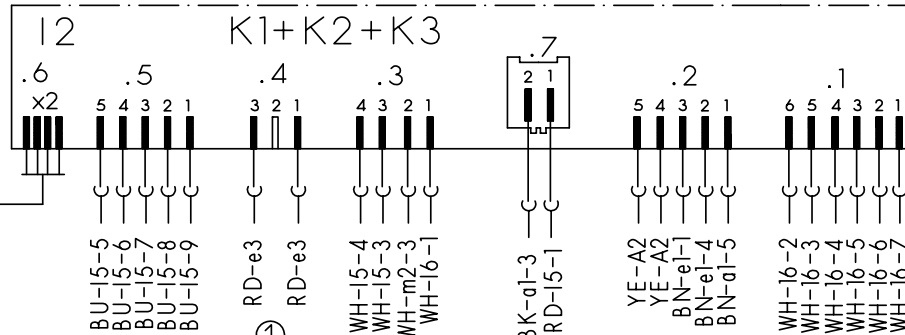
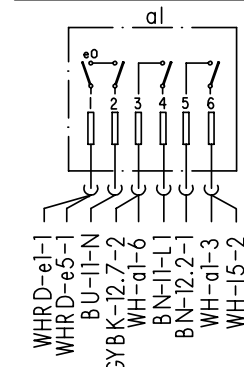
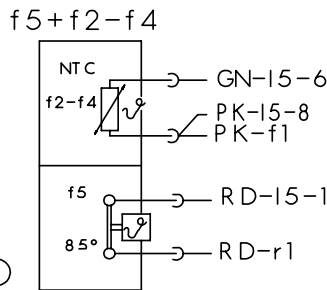

Aqua-Sensor

Schutzleiter

Kupplung

Aktuator

Zugabevorrichtung

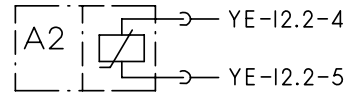

Motor

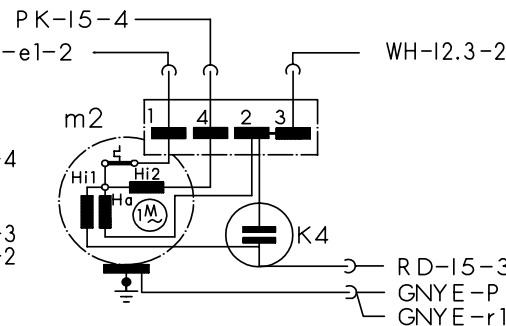

Heizung

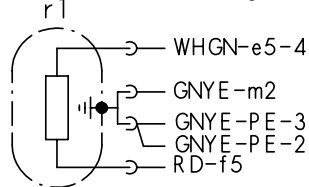

Magnetventile

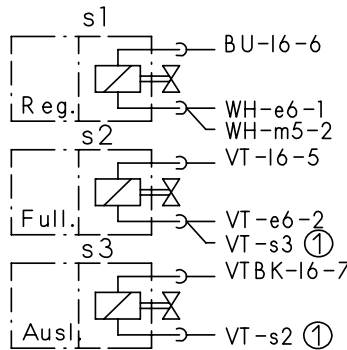

Temperaturregler + NTC

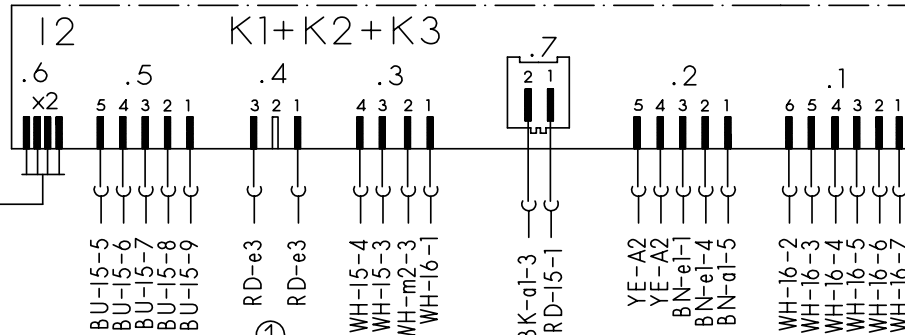
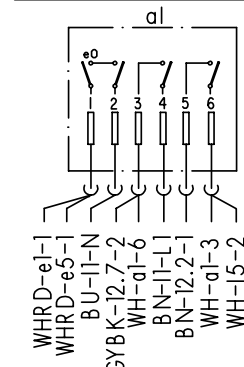
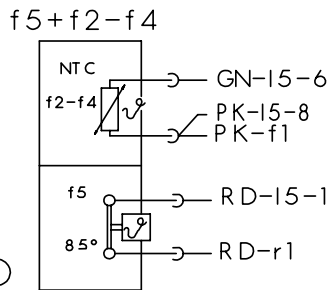

Aqua-Sensor

Schutzleiter

Kupplung

Aktuator

Zugabevorrichtung

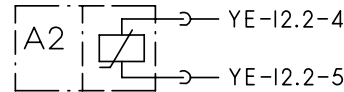

Motor

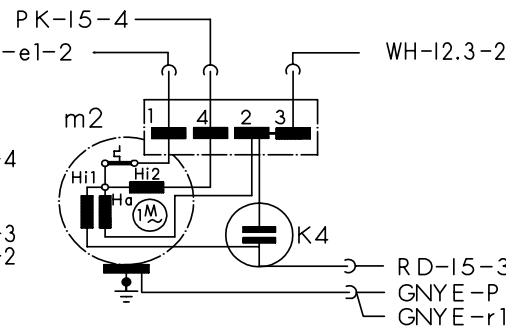

Heizung

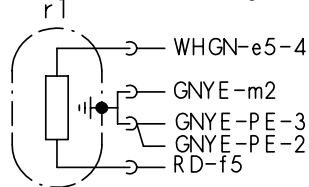

Magnetventile

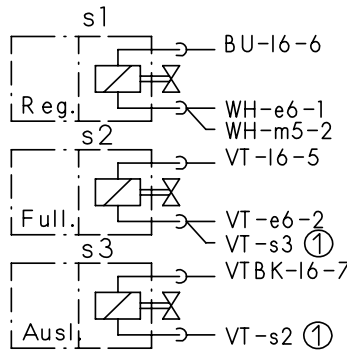

Temperaturregler + NTC

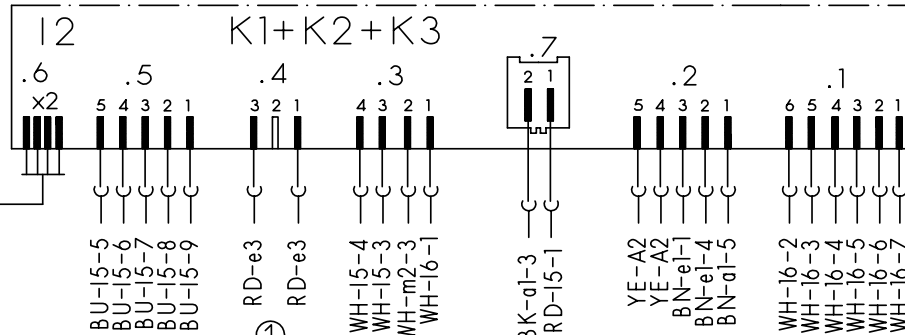
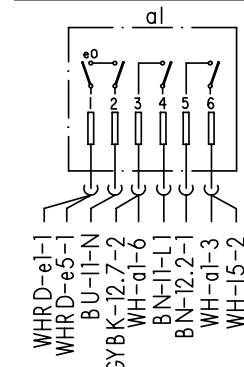
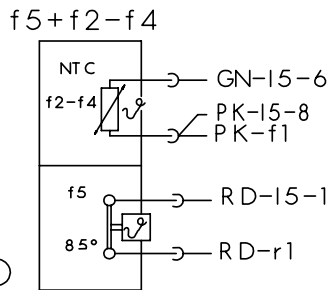

Aqua-Sensor

Schutzleiter

Kupplung

Aktuator

Zugabevorrichtung

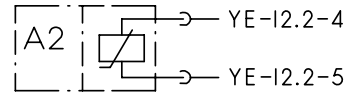

Motor

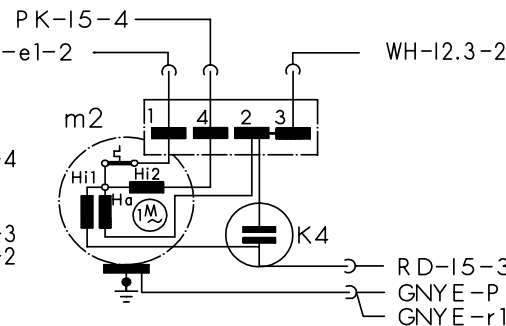

Heizung

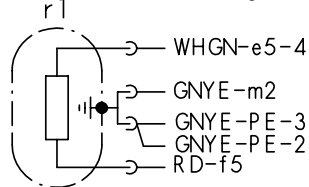

Magnetventile

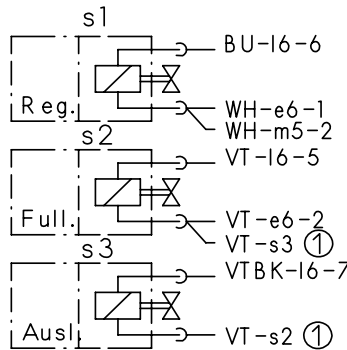

Temperaturregler + NTC

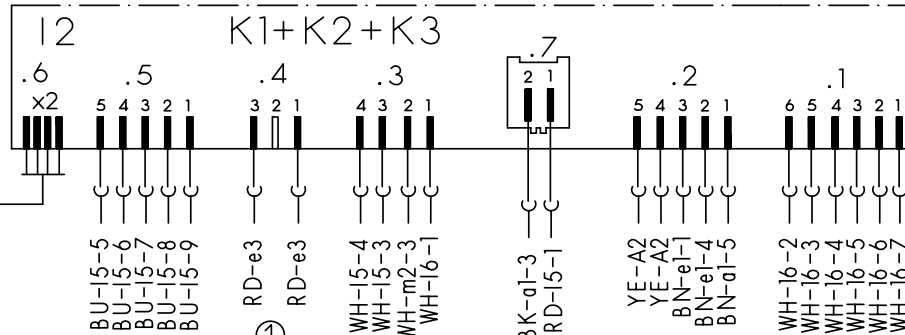
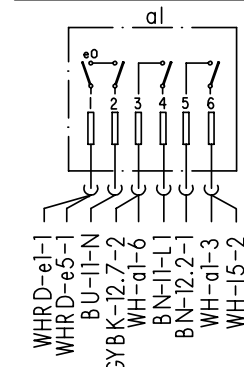
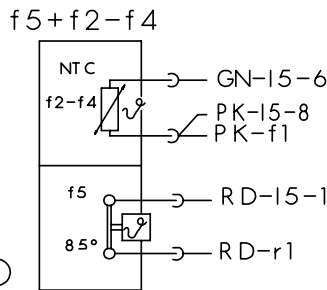

Aqua-Sensor

Schutzleiter

Kupplung

Aktuator

Zugabevorrichtung

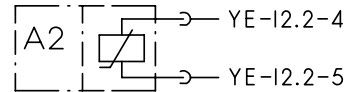

Motor

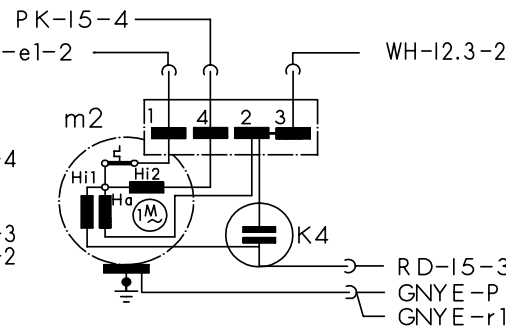

Heizung

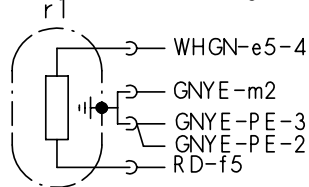

Magnetventile

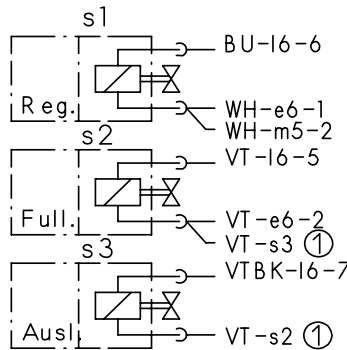

Temperaturregler + NTC

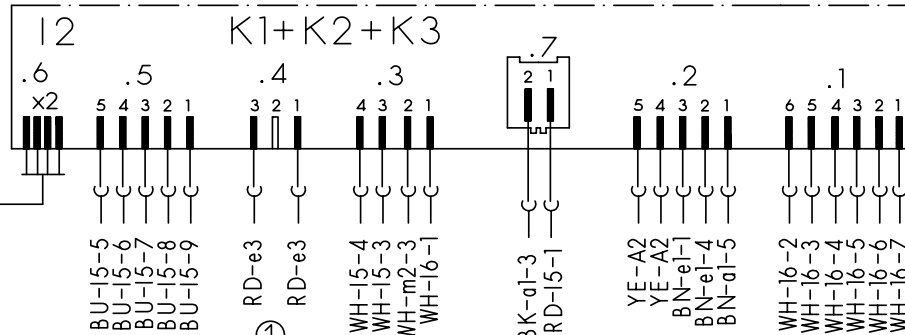
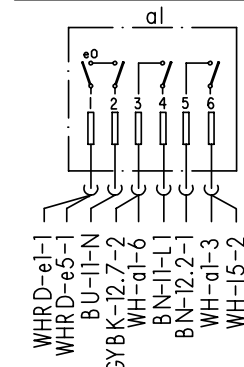
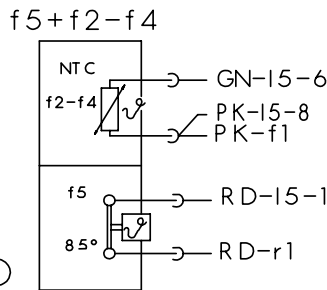

Aqua-Sensor

Schutzleiter

Kupplung

Aktuator

Zugabevorrichtung

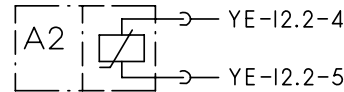

Motor

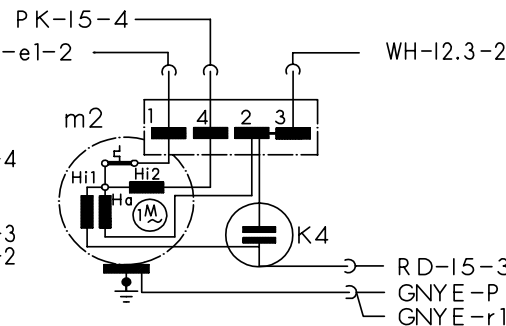

Heizung

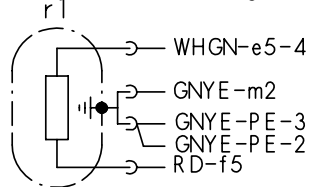

Magnetventile

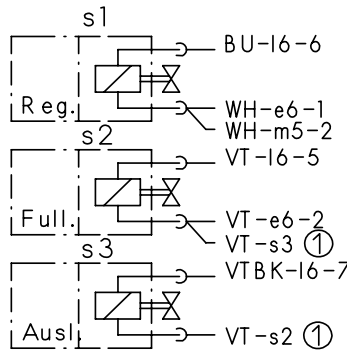

Temperaturregler + NTC

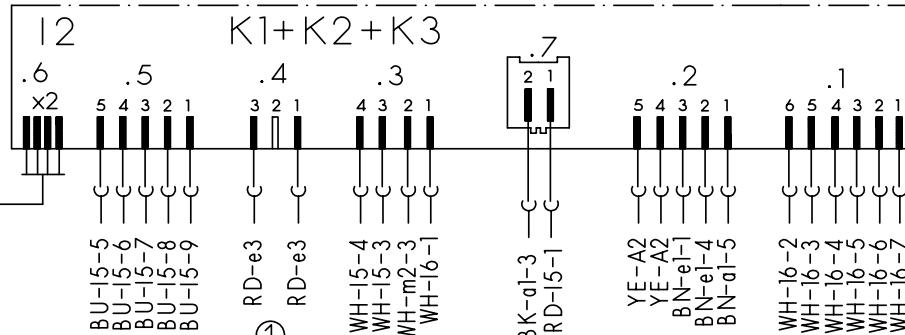
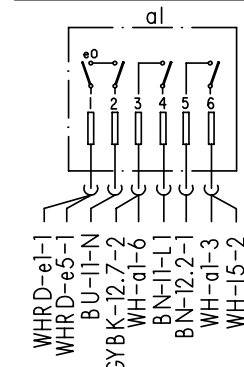
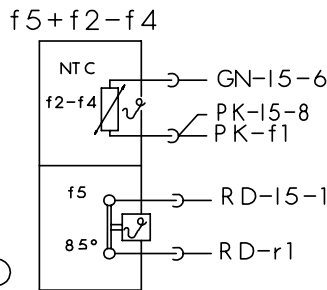

Aqua-Sensor

Schutzleiter

Kupplung

Aktuator

Zugabevorrichtung

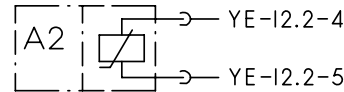

Motor

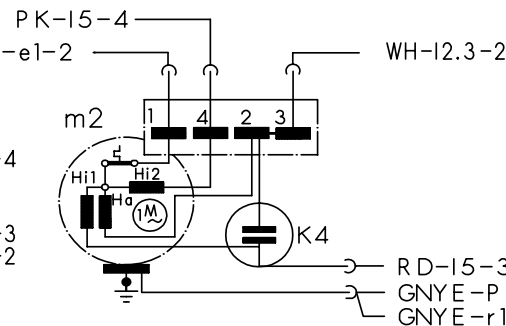

Heizung

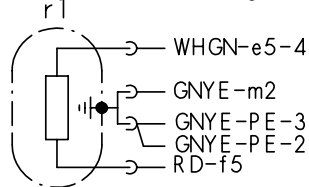

Magnetventile

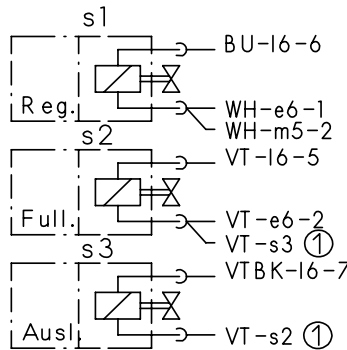

Temperaturregler + NTC

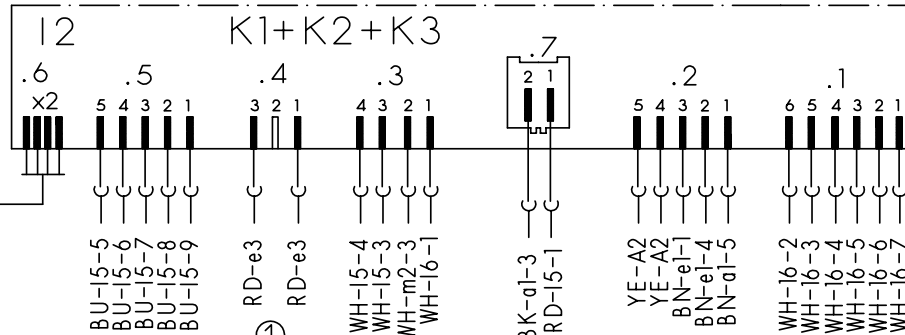
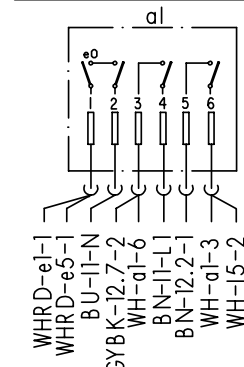
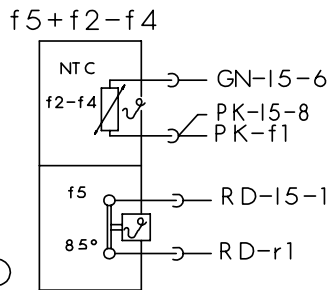

Aqua-Sensor

Schutzleiter

Kupplung

Aktuator

Zugabevorrichtung

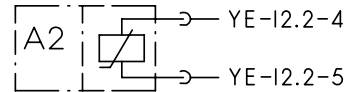

Motor

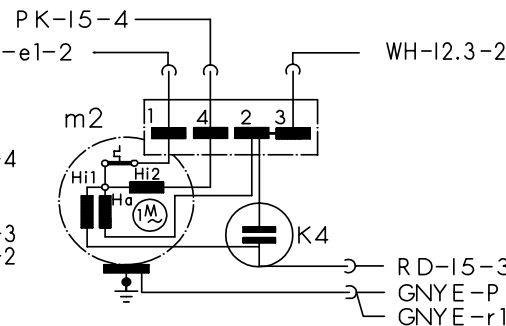

Heizung

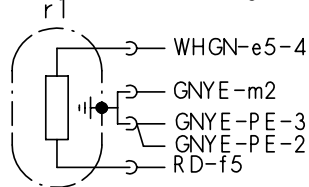

Magnetventile

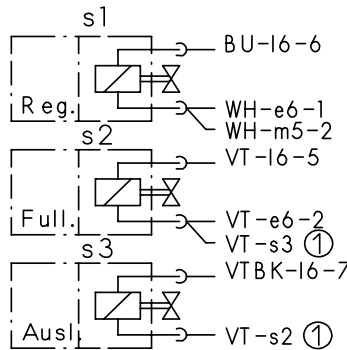

Temperaturregler + NTC

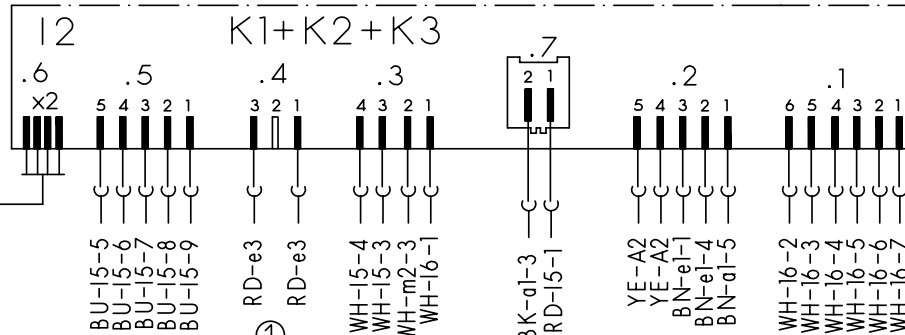
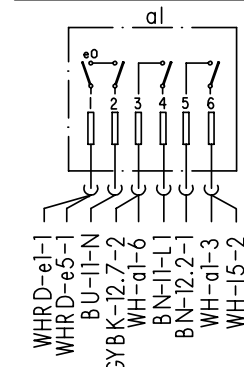
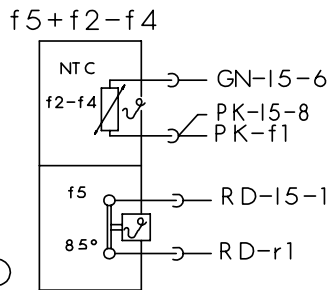

Aqua-Sensor

Schutzleiter

Kupplung

Aktuator

Zugabevorrichtung

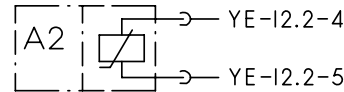

Motor

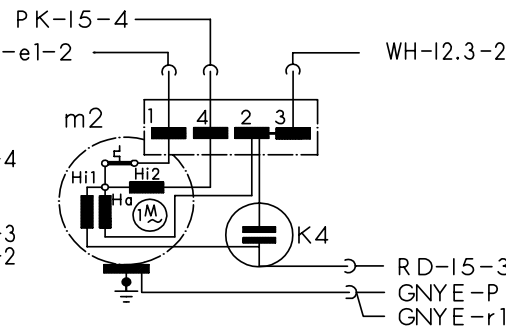

Heizung

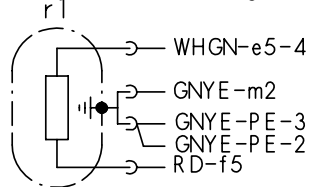

Magnetventile

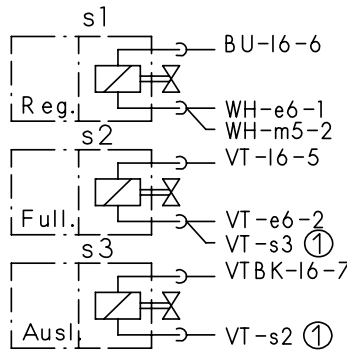

Temperaturregler + NTC

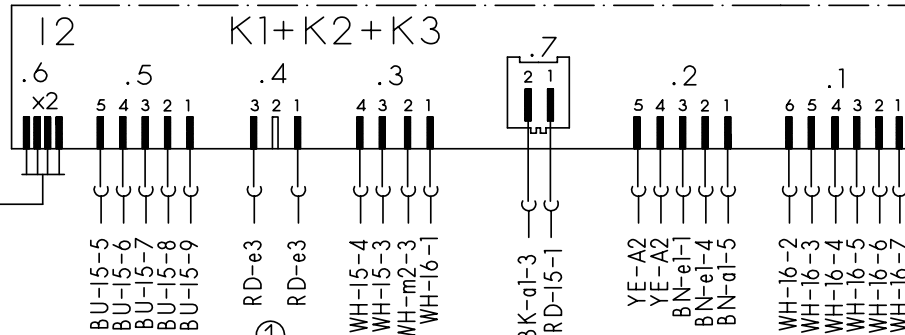
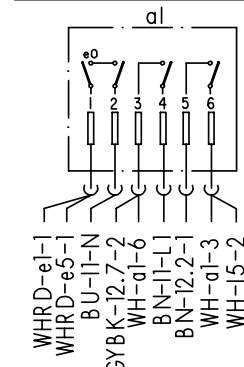
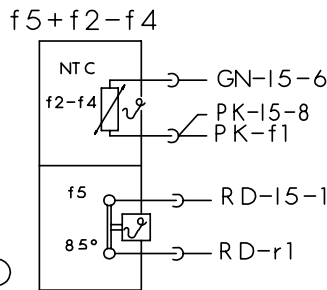

Aqua-Sensor

Schutzleiter

Kupplung

Aktuator

Zugabevorrichtung

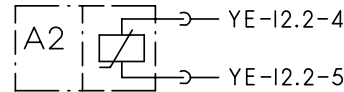

Motor

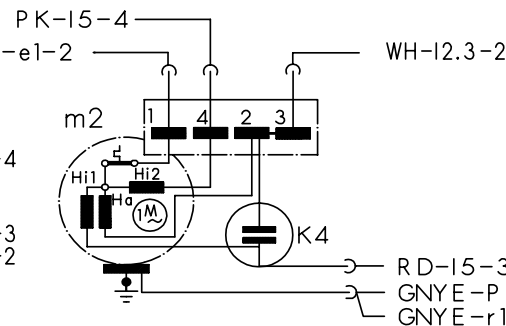

Heizung

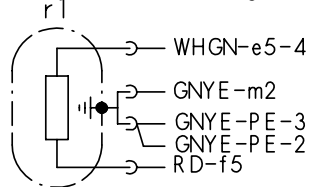

Magnetventile

