





① Fitted depending on features



Designation
Connection Diagram
GV640 II. Gen

LCS
EN
Document No.
5600 0001074481
Material No. 9000505353



Rev
B
Sheet-No.
1
of 1

Function	Actuation	Display				Remarks			
Error class (failure group)		In Customer Service program		At Customer		Appliance behaviour in error case	Results of internal appliance check	Measures	
		LED's	Display	LED	Display				
		Act. Clean Sani End							
		○ ○ ○	E:00				No error		
Interface						Blinking LED's at end of Flash process Stop in current position, no function	Communication issue within electronics	Power cord of the appliance has to be disconnected (to activate on/off from main switch is not enough!) > Verify D-Bus - connectors (3-pole) for electrical connection failure; > Disconnected power cord (plug out and then again plug in); > Repeat flash process; > Change Modul	
Power module		○ ○	E:01			E:01	→ End of program	Pump triggering or pump switching is defect	Change power module
			E:02			E:02	Running w/o heating	Working relay of heating is defect	
			E:03			E:03	Running w/o additional drying system.	Working relay of additional drying system is defect.	
			E:04			E:04	Running w/o heating	Safety relay of heating is defect	
			E:05			E:05	Water switch is running permanently Cancelation of program (Drain)	Impulses w/o activation Water switch triac defect	

Function	Actuation	Display				Remarks			
Error class (failure group)		In Customer Service program		At Customer		Appliance behaviour in error case	Results of internal appliance check	Measures	
		LED's	Display	LED	Display				
		Act. Clean Sani End							
Door			E:06		E:06	Stop in current position, no function	Hall-sensor defect, wire disconnected or power module defect	Power module is functional ok, if plug is disconnected and Hall-sensor is feed with supply voltage. Otherwise change Hall-sensor.	
Heating			E:07		E:07	Function w/o additional drying-system.	Fan defect/blocked Fanelectronic defect	Check component / connection / Measure resistance => only dishwashers with additional drying system	
			E:08			Function w/o heating.	Heat pump detects too low water level in sump. Low voltage	>heat exchanger drain valve is leaky >Overturned bowls / pots in appliance? No device error!	
			E:09		E:09			Heating-circuit is intermittent (resistance, wire harness, safety relais pins on power module)	Measure heating resistance, check wires
			E:10				Function w/o additional drying-system.	Heating-circuit additional drying system is intermittent (resistance/wire harness) Fanelectronic defect Failure in wire to fan	Check water hardness; if necessary decalcify and clean. On repeat change heat pump. Check component Connection? => only dishwashers with additional drying system
			E:11		E:11		Function w/o heating.	NTC-failure Failure in wire to NTC's	Measure NTC's, check wires.
			E:12						Reserved

Function	Actuation	Display				Remarks		
Error class (failure group)		In Customer Service program		At Customer		Appliance behaviour in error case	Results of internal appliance check	Measures
		LED's	Display	LED	Display			
		Act. Clean Sani End						
			E:13				Water temperature too high (> 75°C)	Safety measure - no failure! Check water inlet temperature .

Function	Actuation	Display	Remarks					
Error class (failure group)		In Customer Service program		At Customer		Appliance behaviour in error case	Results of internal appliance check	Measures
		LED's	Display	LED	Display			
		Act. Clean Sani End						
Filling			E:14		E:14	Program abort with draining	Flow sensor detects no impulses, even though circulation pump detects water.	Check wires, check flow sensor (Reed-switch)
						Program abort with interval pumping	Safety switch base carrier active. Appliance can't be turned off.	Look / Search for cause of water in base carrier
						Water inlet (impulses from flow sensor) w/o activation of filling valve.	Check filling valve. Check triggering of filling valve.	
						Program abort with draining	Water inlet amount according flow sensor too high	Check flow control in filling valve
						Waiting for water inlet. Program abort with draining	Water inlet amount according flow sensor too low or no water intake.	Check water inlet
Circulation pump			E:19		E:19		Reserved	
						→ End of program	Wrong resistance value of circulation pump	Check wires, measure coil.
						→ End of program	Circulation pump blocked	Check for foreign objects, if necessary renew
Drainpump			E:22		E:22	→ End of program	Water in pump sump, because of dirt filters.	Clean filters.
						→ End of program	Wrong resistance value of drain pump	Check wires, measure coil
						→ End of program	Draining not possible. Pump cover missing?	Check water draining (hose kinked / blocked, pressure head, pump cover). Install pump cover.
						Check valve leaky	Inspect check valve	
			E:25		E:25	→ End of program	Drain pump blocked; possibly pump cover is missing	Check for foreign objects. Install pump cover

Function	Actuation	Display	Remarks					
Error class (failure group)		In Customer Service program		At Customer		Appliance behaviour in error case	Results of internal appliance check	Measures
		LED's	Display	LED	Display			
		Act. Clean Sani End						
Waterswitch			E:26			Permanent activation of water switch	Impulses from water switch are missing despite triggering	Check wires. Measure supply voltage on motor. Check switch of water switch
			E:27					Reserved
Aquasensor			E:28			Function w/o aquasensor	Calibration of aquasensor not successful	Check wires. Dirt on aquasensor. Is appliance serially equipped with aquasensor?
General			E:29			No correct functions / Bad washing/drying result possible	Lowvoltage (<190V)	No device error!
			E:30			Dishwasher switches off themself	Overvoltage (>290V)	No device error!
			E:31				Reserved	
			E:32				Reserved	

Function	Display	Remark				
	Display	Can be skipped	Time (s)	Value	Check / Measure	Remark

1.1 Customer Service Program

Preparation					Remove approx. 0.5 l water from salt dispenser.	Regeneration valve must be checked for leaks at appropriate customer specifications (see also steps with display S:04 + S:17)
CoilCheck	S:00	No	approx 20			Check the drain pump. Activate the drain pump and place the water switch in the top basket position.
Check flow sensor and flow controller	S:01	No	approx . 10-100			Add 50 ml (filling valve, drainage pump and circulation pump are activated in succession).
Pause	S:02	No	10			
Fill + pump	S:03	No	approx 100			Heat exchanger is overfilled, residual quantity in the pump sump is pumped off ==> heat exchanger full (contains 3.1 l water).
Pause	S:04	No	10		Visual inspection: water level in salt dispenser.	No change to water level ==> Regeneration valve leakproof.
Fill	S:05	No	approx 40	1,5 l	Check waterinlet amount	Within of 40s should the filling amount achieved. The heat exchanger will be overfilled.
Pause	S:06	No	10		Visual inspection: water level in appliance.	Water level on upper edge of fine mesh filter (= 1.5 l in pump sump).
Fill	S:07	No	approx 60	2,5 l		Total: 4 l in appliance
Circulate	S:08	No	15			Circulation pump must not "snorkel".
Dispense (detergent)	S:09	No	10			

BSH BOSCH UND SIEMENS HAUSGERAETE GMBH	Document-No.: 56000000171137 ASP EN	Revision A	Seite-Nr.
Function Test Program	Material-No.: 9000.541.213		1 of 3
The reproduction, transmission or use of this document or its contents is not permitted without express written authority. Offenders will be liable for damages. All rights including rights created by patent grant or registration of a utility model or design are reserved. Copyright reserved.			



Function	Display	Remark				
	Display	Can be skipped	Time (s)	Value	Check / Measure	Remark
Circulate + heat + calibrate AquaSensor	S:10	Nein	110			
Circulate + heat	S:11	Yes		40 °C		Increase of temperature during heating +2.5 °C/min
Pause	S:12	No	5			
Circulate + dispense (rinse aid)	S:13	No	60			Number of impulses = set value of dispensed rinse aid
Circulate + heat + change position of water switch	S:14	Yes	approx 480	65 °C		Increase of temperature during heating +2.5 °C/min. Change every 30 s roof shower head, top basket, bottom basket.
Pump off	S:15	No	45			Tightness test of outlet valve Water-level at heat exchanger is not supposed to falling off
Drain heat exchanger	S:16	No	60			Check outlet valve
Pause	S:17	No	10		Visual inspection: water level in appliance.	Water level must be over handle of coarse filter
Pump off + drain heat exchanger + fill + regenerate	S:18	No	approx 20			Drain the complete appliance
Pause	S:19	No	10		Visual inspection: water level in salt dispenser.	Water level in salt dispenser must be increased by several cm.
Pump off + drain heat exchanger + fill	S:20	No	approx 100	4 l		Rinse the brine solution out of the heat exchanger and pump sump.



Function	Display	Remark				
	Display	Can be skipped	Time (s)	Value	Check / Measure	Remark
Pump off + drain (heat exchanger)	S:21	No	30			Drain the complete appliance
Check whether appliance was drained (activates circulation pump and drain pump)	S:22	No	approx 10-120			Self-check whether appliance was drained.
End of test programme	„0“ on display or „End LED“ is lit				Switch off main switch	Test has ended. When the appliance is next switched on, the normal rinse programme is displayed



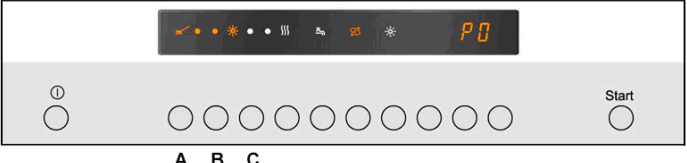

1.2 Reset program







Reset					Perform reset	Is possible at any time by pressing the button "Start" for longer than 3 seconds

Function	Actuation	Display	Remark
----------	-----------	---------	--------

Operating diagram			Button name Panels are by way of example, different designs are possible
			
			

Reset * * Before selecting the special programmes, perform a reset			Appliance is switched on
		0:01	Press "Start" button for 3 seconds

Select special programmes			Switch off the appliance
			Press and hold down buttons "B" + "C"
			Press the main switch
		P0	Release buttons when P0 is displayed

Function	Actuation	Display	Remark
Select special Selection		P0...P7	Press button "B" until required programme is selected
		P0 P1 P2 P3 P4 P5 P6 P7	Error memory Customer service test programme Not relevant to customer service Not relevant to customer service Not relevant to customer service Not relevant to customer service Not relevant to customer service Demonstration programme
Read out fault memory		P0	Activate: Press button "C"
		C:00...C:07 E:00...E:32	Storage space number: Hold down button "C" Storage space contents (fault code): Release button "C"
Customer service test programme		P1	Press button "B" until P1 is displayed
		S:00...S:xy	Activate: Press button "C"
Skip test step		S:00...S:xy	Press button "B" Not all test steps can be skipped (see customer service test programme)

Function	Actuation	Display	Remark
End special programmes In the error memory (P0)	① A B C ↑	Start ○	Switch off main switch
In the customer service test programme (P1)	① A B C	Start ○ ↑	0:01 Press "Start" button for 3 seconds (Reset)
	① A B C ↑	Start ○	Switch off main switch
Select demonstration programme	① A B C ↑	Start ○	P7 Press button "B" until P7 is displayed
	① A B C ↑	Start ○	1:23 Activate: Press button "C"
	Door		If operation from front: Open and close door again If operation from above: Close and open door and close again
End demonstration programme	Door		Only if operation from above: When programme is running, open door
	① A B C	Start ○ ↑	0:01 Press "Start" button for 3 seconds (Reset)
	① A B C ↑ ↑	Start ○	Hold down buttons "B" + "C"
	① A B C ↑	Start ○	Switch off main switch

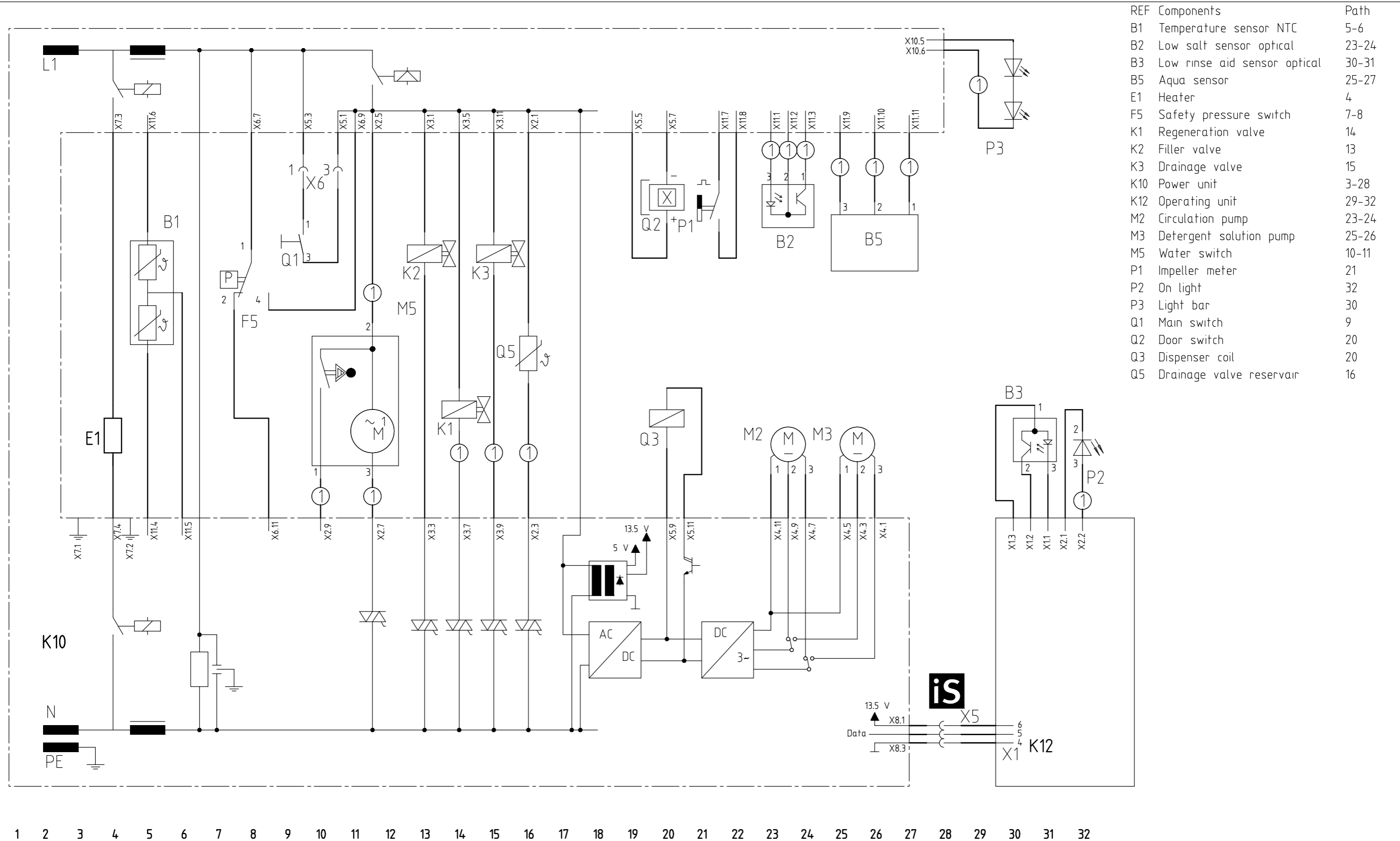

REF	Components	Path
B1	Temperature sensor NTC	5-6
B2	Low salt sensor optical	23-24
B3	Low rinse aid sensor optical	30-31
B5	Aqua sensor	25-27
E1	Heater	4
F5	Safety pressure switch	7-8
K1	Regeneration valve	14
K2	Filler valve	13
K3	Drainage valve	15
K10	Power unit	3-28
K12	Operating unit	29-32
M2	Circulation pump	23-24
M3	Detergent solution pump	25-26
M5	Water switch	10-11
P1	Impeller meter	21
P2	On light	32
P3	Light bar	30
Q1	Main switch	9
Q2	Door switch	20
Q3	Dispenser coil	20
Q5	Drainage valve reservoir	16

① Fitted depending on features

Designation Circuit Diagram GV 640 II Generation	LCS EN	Document No. 5600 0001073685	Rev B	Sheet-No. 1
		Material No. 9000505352		of 1