

Ansicht von vorn
Ansicht von hinten

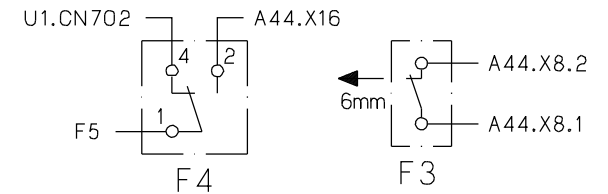

Legende auf
Stromlaufplan

56500941951P01	02.06.2004
HB 84K550S	

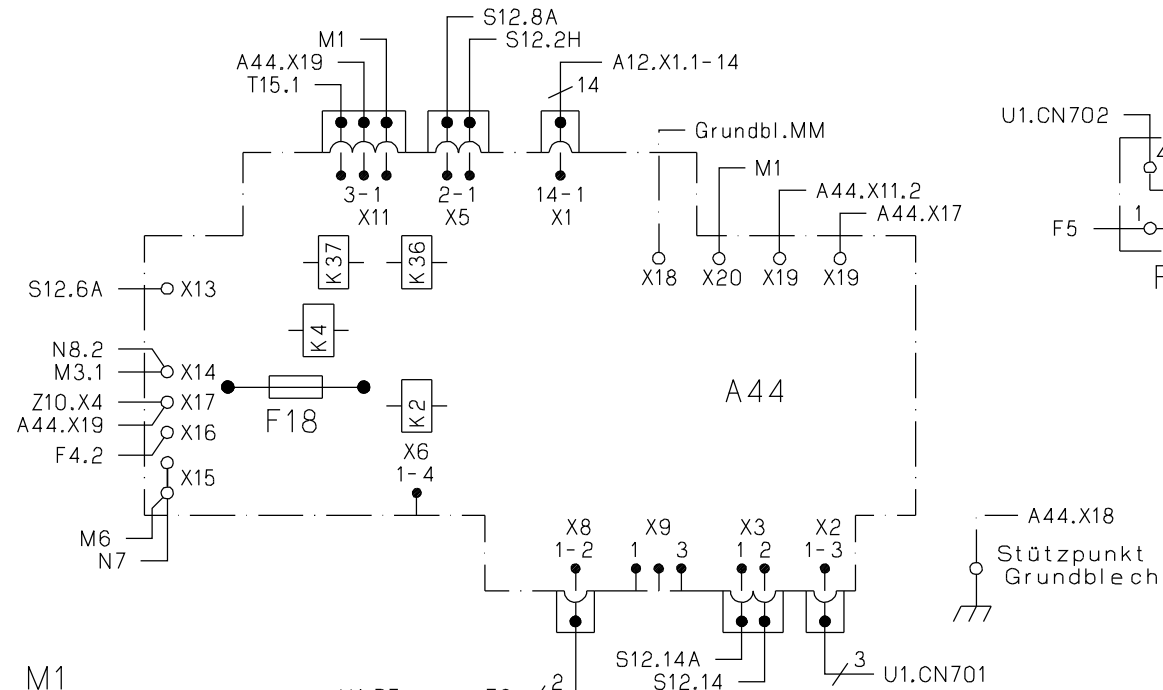
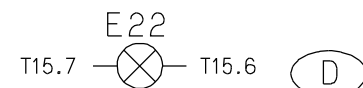
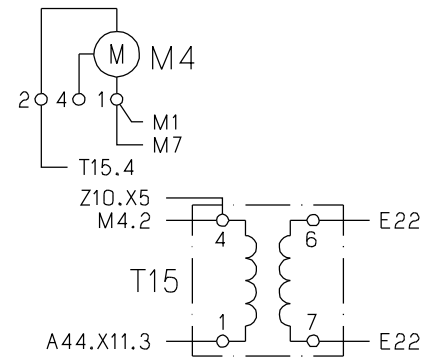
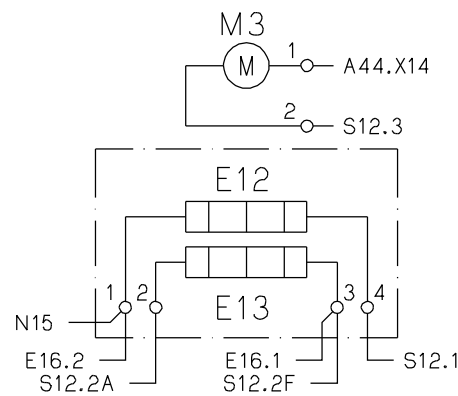
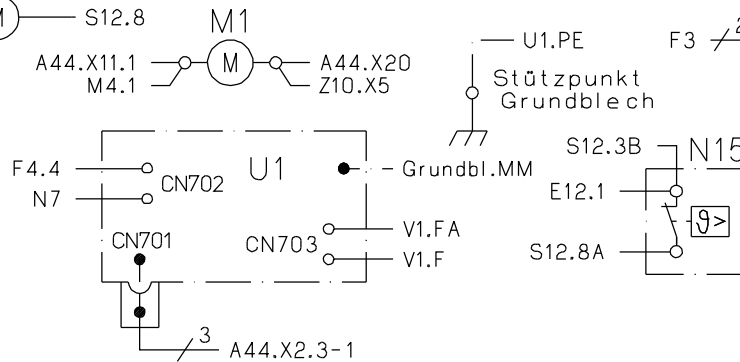
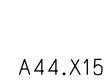
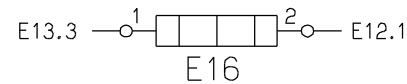
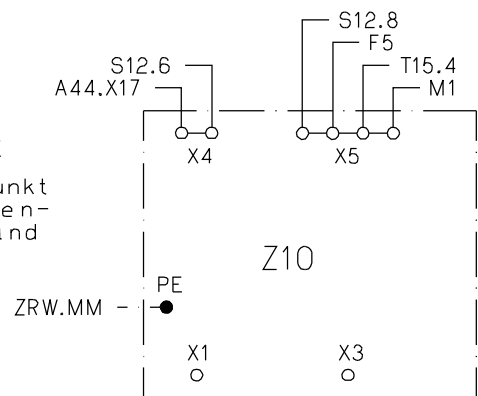
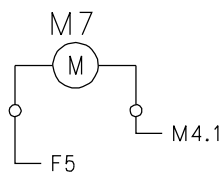
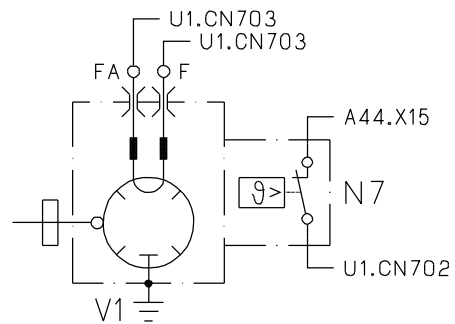
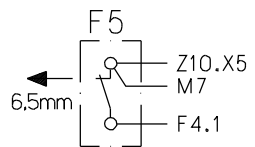
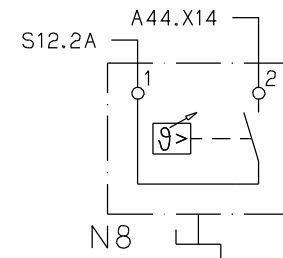
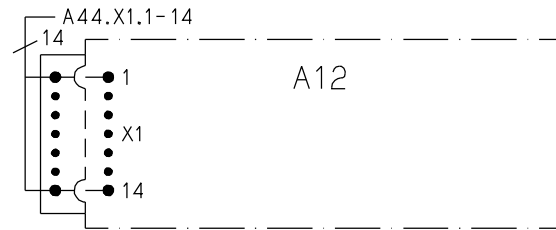
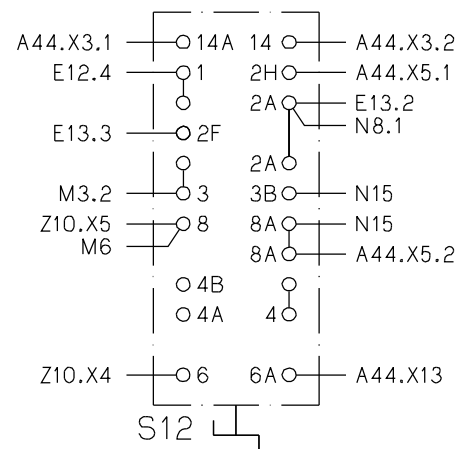

as seen from the front
as seen from the back

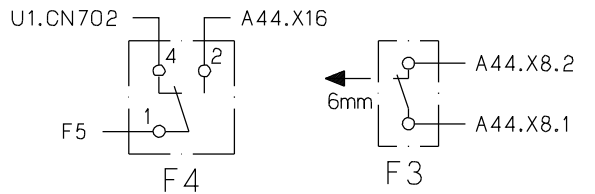
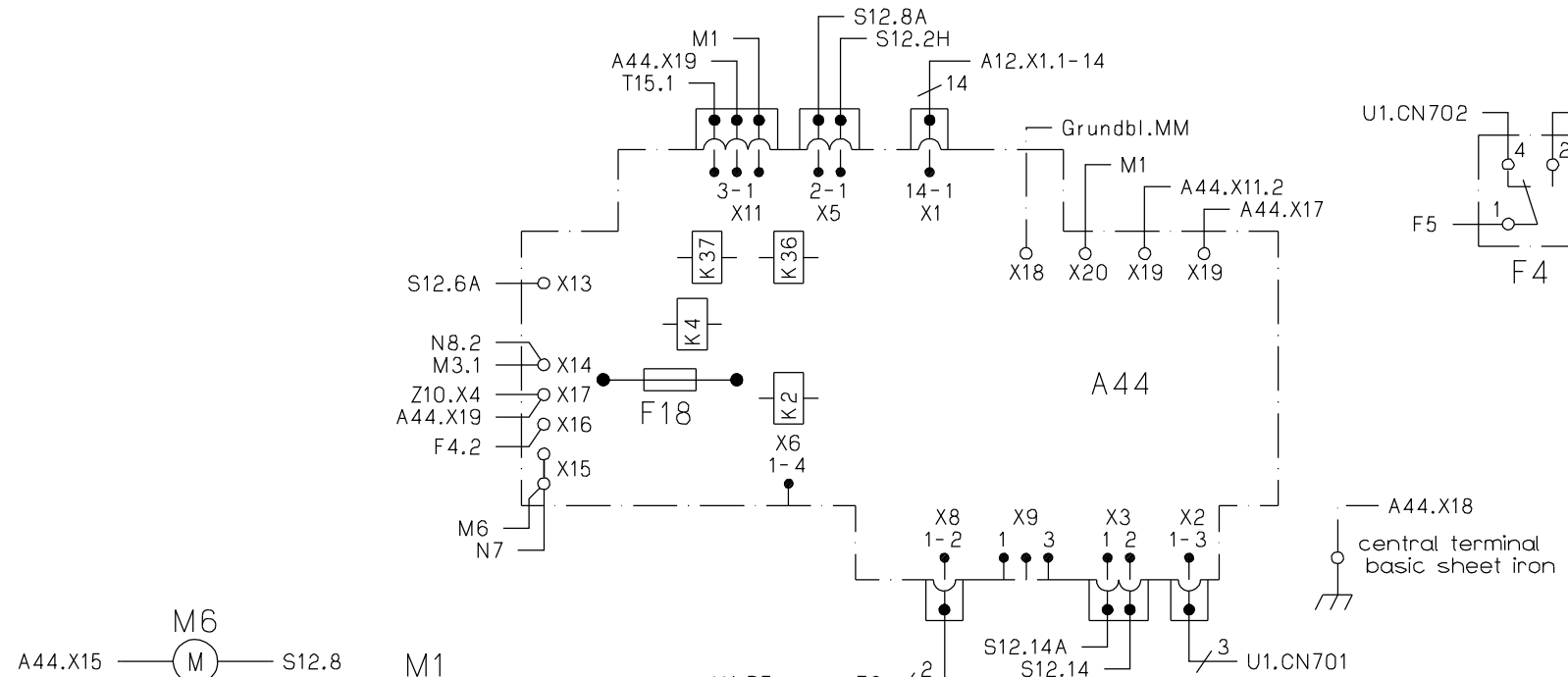
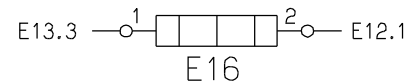
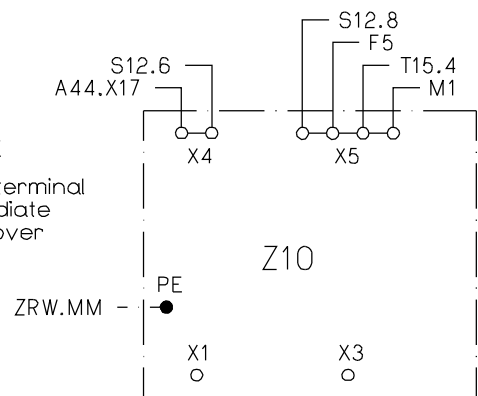
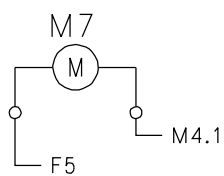
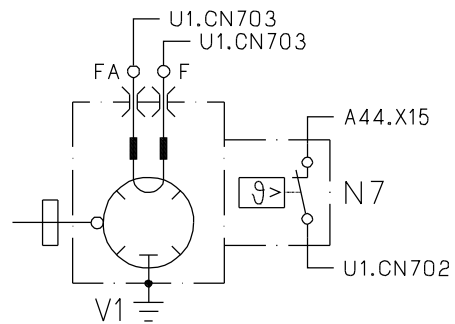
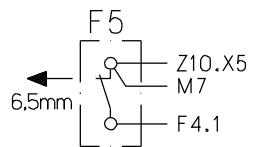

legend see wiring diagram

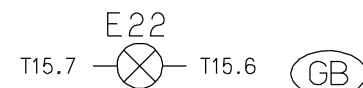
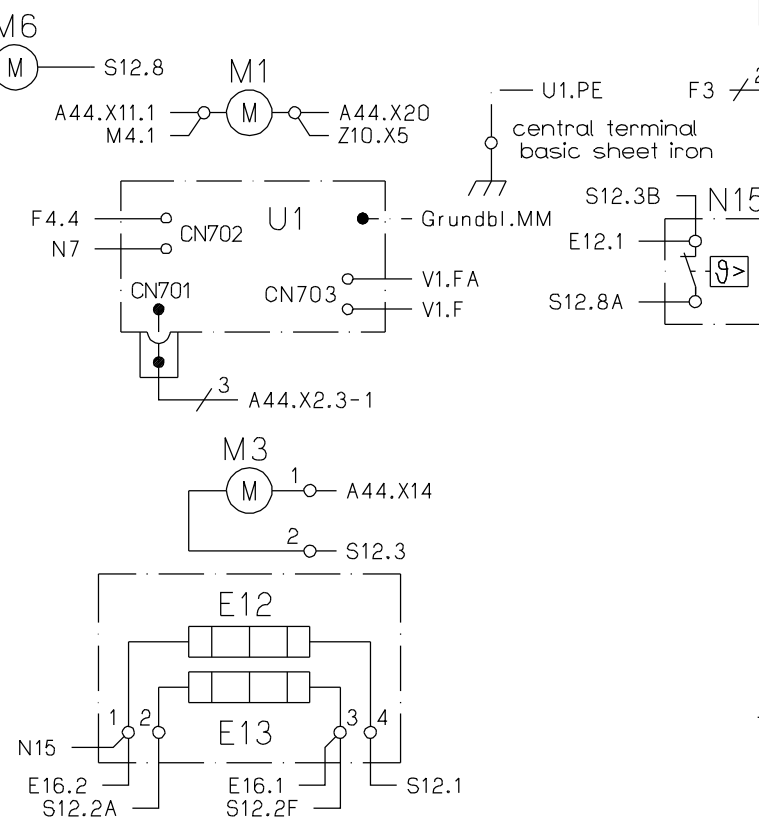

56500941951P01	02.06.2004
HB 84K550S	

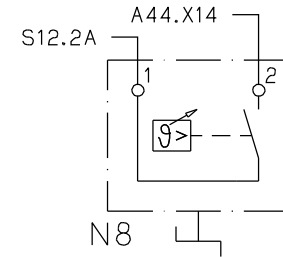
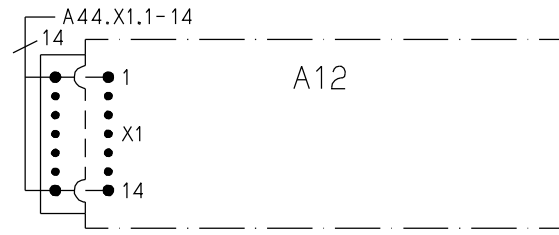
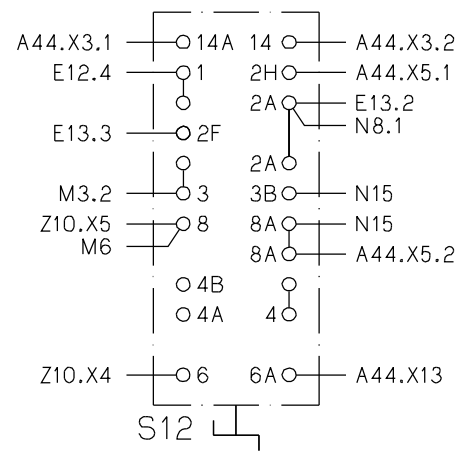

vue de l'avant
vue de l'arrière

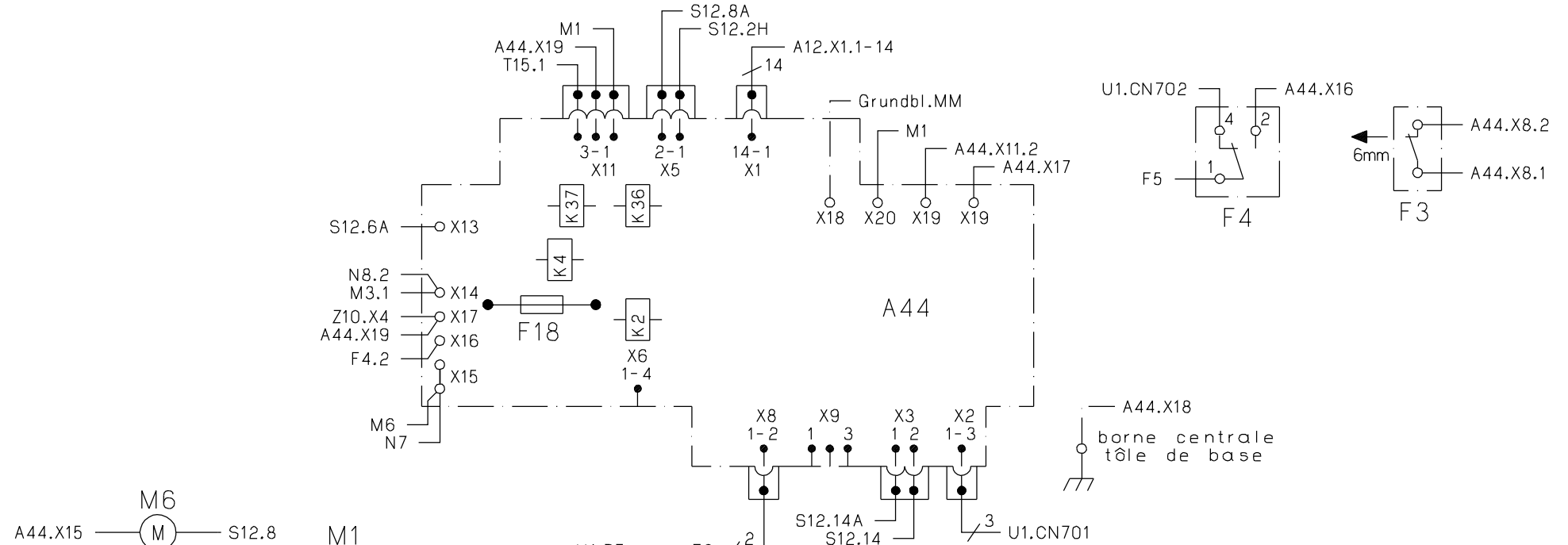
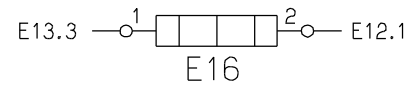
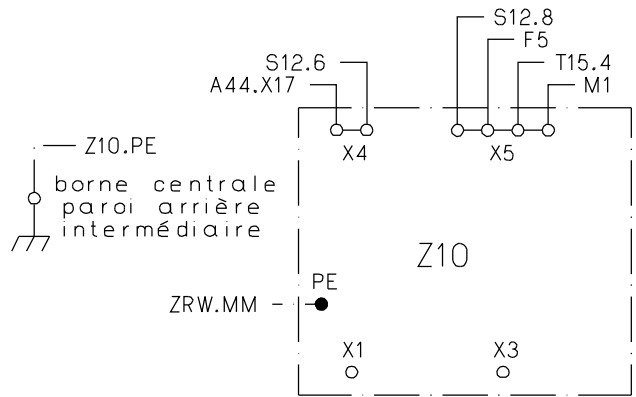
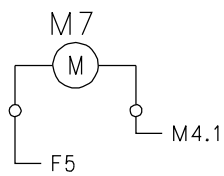
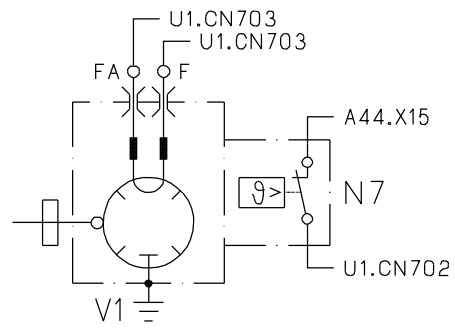
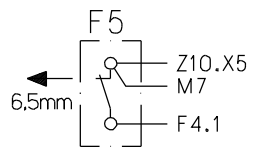

légende voir schéma de principe

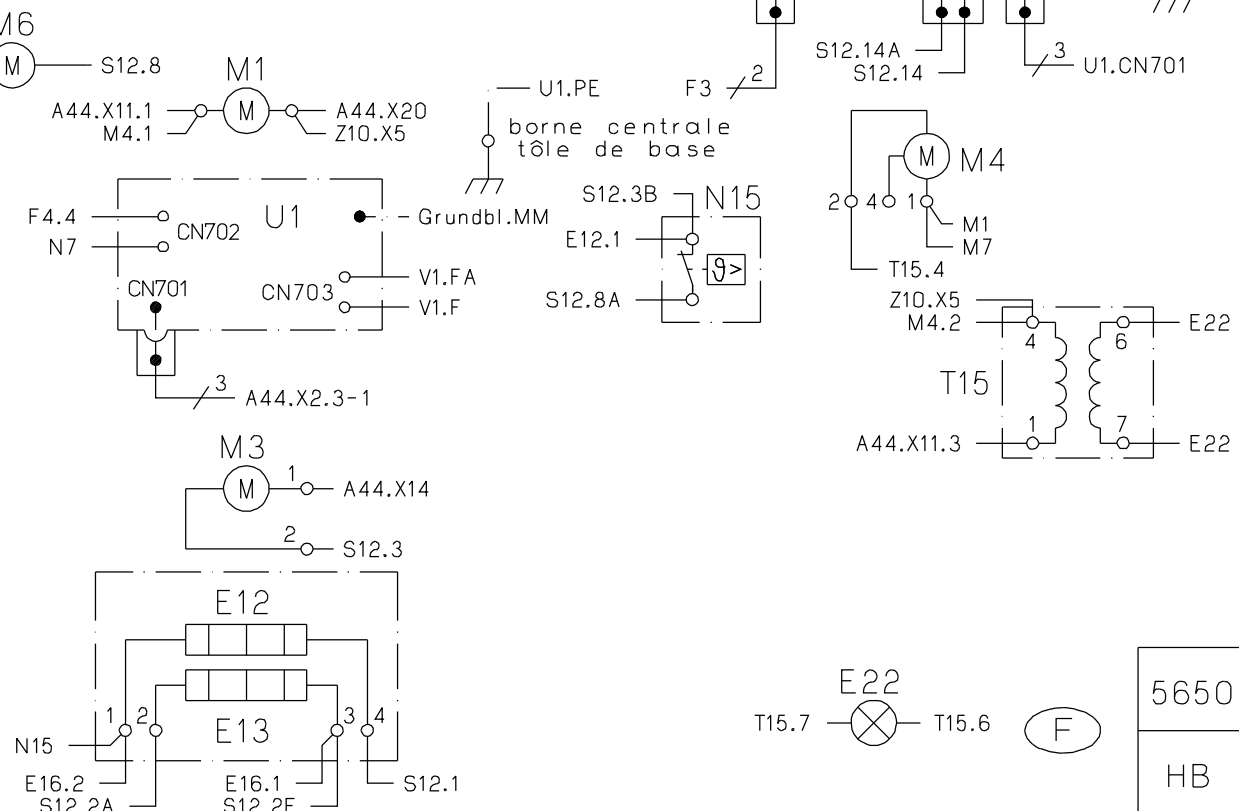

56500941951P01	02.06.2004
HB 84K550S	

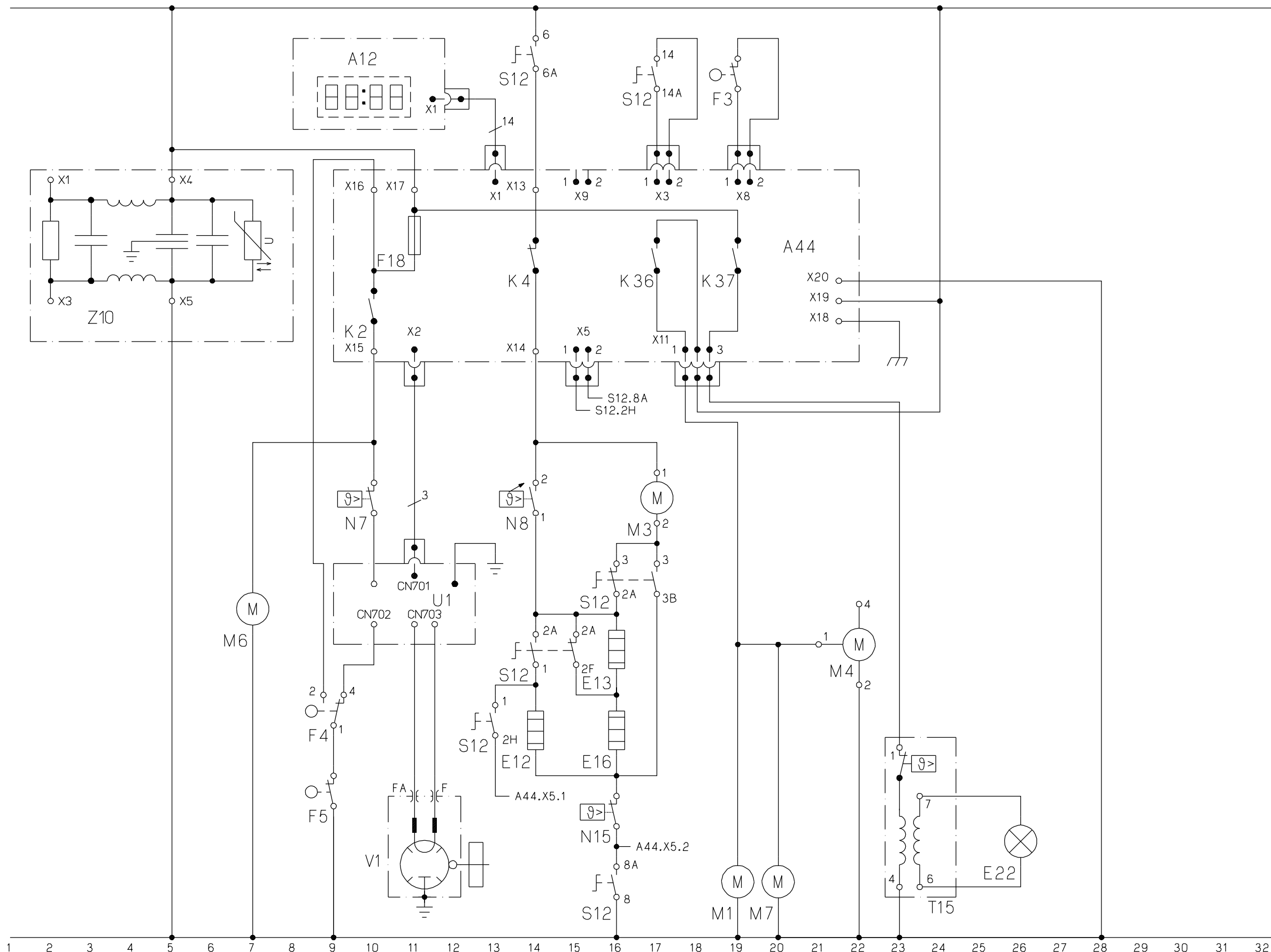

A12	Eingabe - /Anzeige-Platine	8-12
A44	Steuerplatine	9-22
E12	Unterhitze 450W/230V	14
E13	Unterhitze 528W/82V	16
E16	Grillheizkörper 2150W/230V	16
E22	Backofenlampe 20W	26
F3	Sicherheitsschalter	19
F4	Sicherheitsschalter	9
F5	Sicherheitsschalter	9
F18	Sicherung 8A	11
K2	Leistungsrelais	10
K4	Leistungsrelais	14
K36	Steuerrelais	17
K37	Steuerrelais	19
M1	Kühlgebläse motor	19
M3	Umluftmotor	17
M4	Wrasenlüfter	22
M6	Antennenmotor	7
M7	Magnetronlüfter	20
N7	Temperaturbegrenzer	10
N8	Backofenregler	14
N15	Temperaturbegrenzer	16
S12	Vorwählschalter	13-17
T15	Netztrafo	23
U1	Inverter	9-12
V1	Magnetron	11/12
Z10	Funkentstörfilter	2-8

Diagramm:56500942534P01

Sicherheitsschalter bei geschlossener Tür

(D)

56500941951P02	02.06.2004
HB 84K550S	

current path

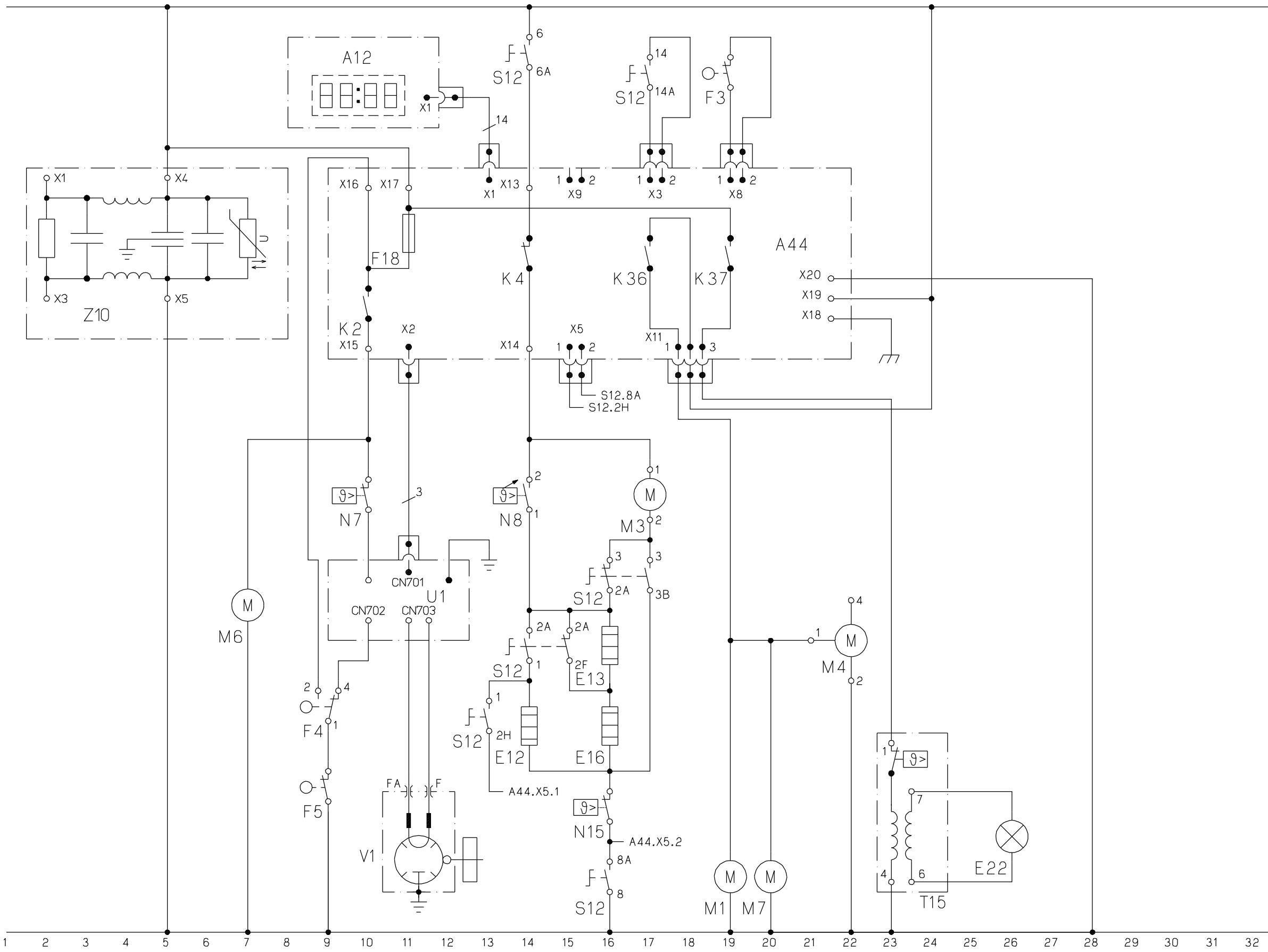

A12	input-/indicator-p.c.b.	8-12
A44	control p.c.b.	9-22
E12	bottom element 450W/230V	14
E13	bottom element 528W/82V	16
E16	grill element 2150W/230V	16
E22	oven lamp 20W	26
F3	safety switch	19
F4	safety switch	9
F5	safety switch	9
F18	fuse 8A	11
K2	power relay	10
K4	power relay	14
K36	control relay	17
K37	control relay	19
M1	cooling blower	19
M3	air circulating motor	17
M4	vapour blower	22
M6	motor for antenna	7
M7	magnetron blower	20
N7	temperature limiter	10
N8	oven thermostat	14
N15	temperature limiter	16
S12	pre-selection switch	13-17
T15	mains transformer	23
U1	inverter	9-12
V1	magnetron	11/12
Z10	interference suppressor	2-8

diagram:56500942534P01

safety switches by closed door



56500941951P02	02.06.2004
HB 84K550S	

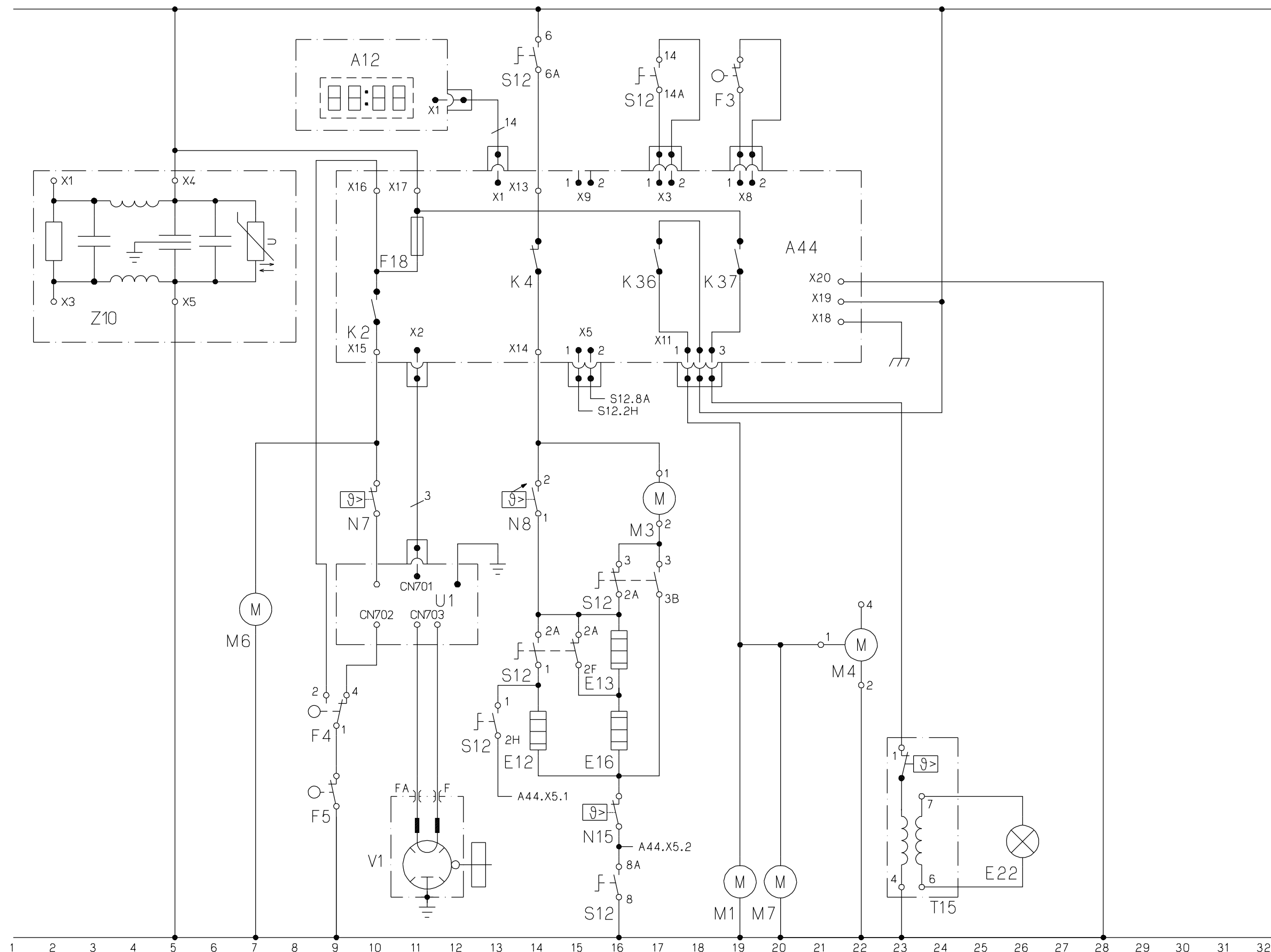

A12	platine de visualisat. et de prog.	8-12
A44	platine de commande	9-22
E12	résistance de sole 450W/230V	14
E13	résistance de sole 528W/82V	16
E16	résistance grilloir 2150W/230V	16
E22	éclairage du four 20W	26
F3	interrupteur de sécurité	19
F4	interrupteur de sécurité	9
F5	interrupteur de sécurité	9
F18	fusible 8A	11
K2	relais de puissance	10
K4	relais de puissance	14
K36	relais de commande	17
K37	relais de commande	19
M1	ventilateur	19
M3	turbine de ventilation	17
M4	ventilateur de refroidissement	22
M6	moteur d'entraînement de l'antenne	7
M7	ventilateur du magnétron	20
N7	limiteur de température	10
N8	thermostat du four	14
N15	limiteur de température	16
S12	sélecteur	13-17
T15	transformateur au réseau	23
U1	inverseur	9-12
V1	magnétron	11/12
Z10	filtre d' antiparasitage	2-8

diagramme:56500942534P01

interrupteurs de sécurité (porte fermée)

(F)

56500941951P02	02.06.2004
HB 84K550S	