

Ansicht von vorn  
Ansicht von hinten

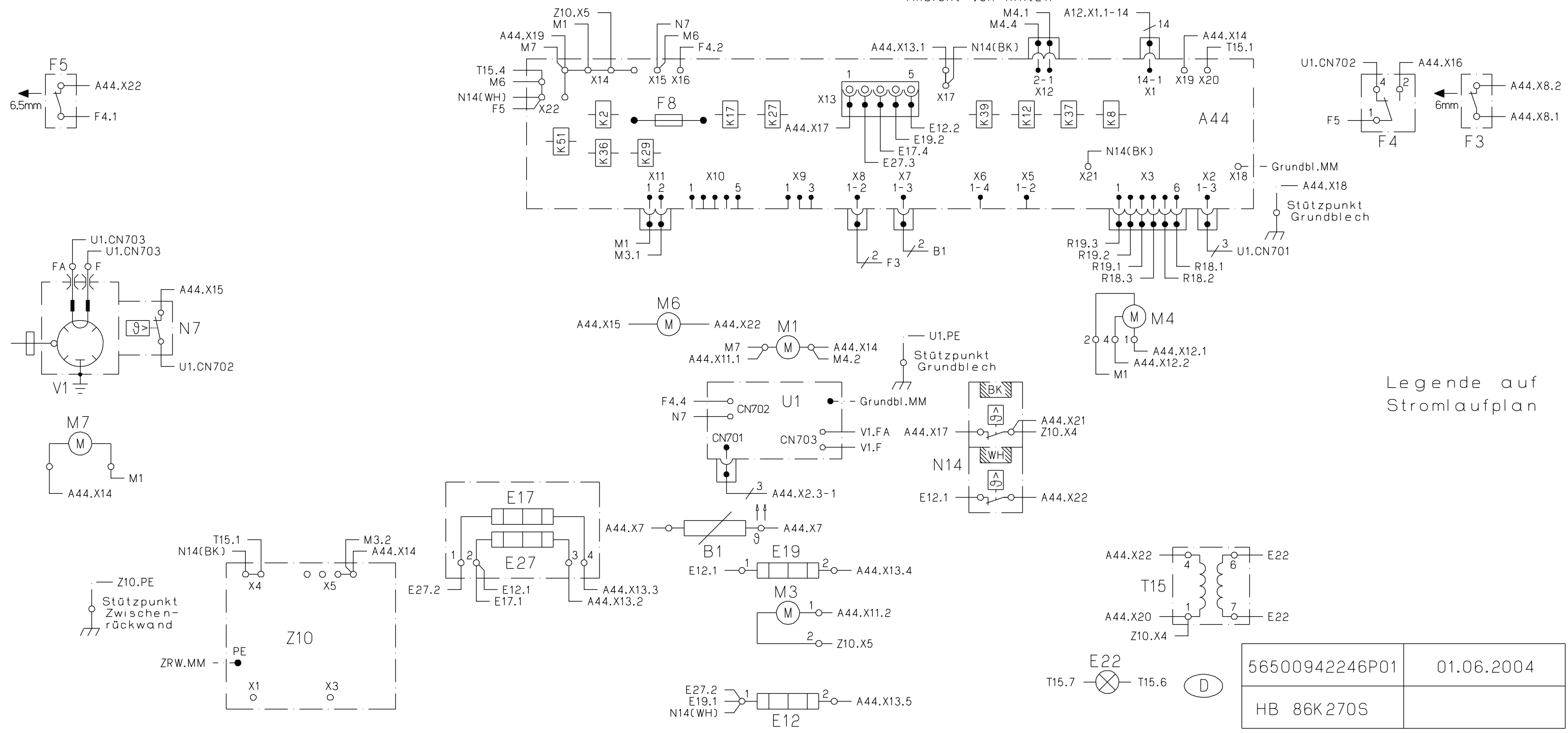

Legende auf Stromlaufplan

56500942246P01	01.06.2004
HB 86K270S	

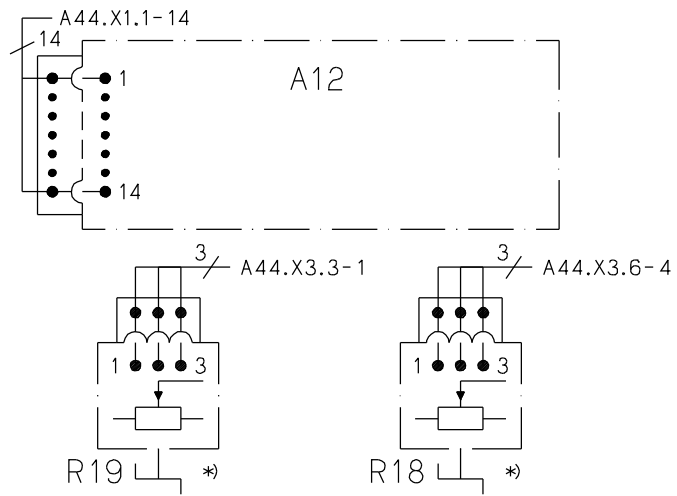

as seen from the front  
as seen from the back

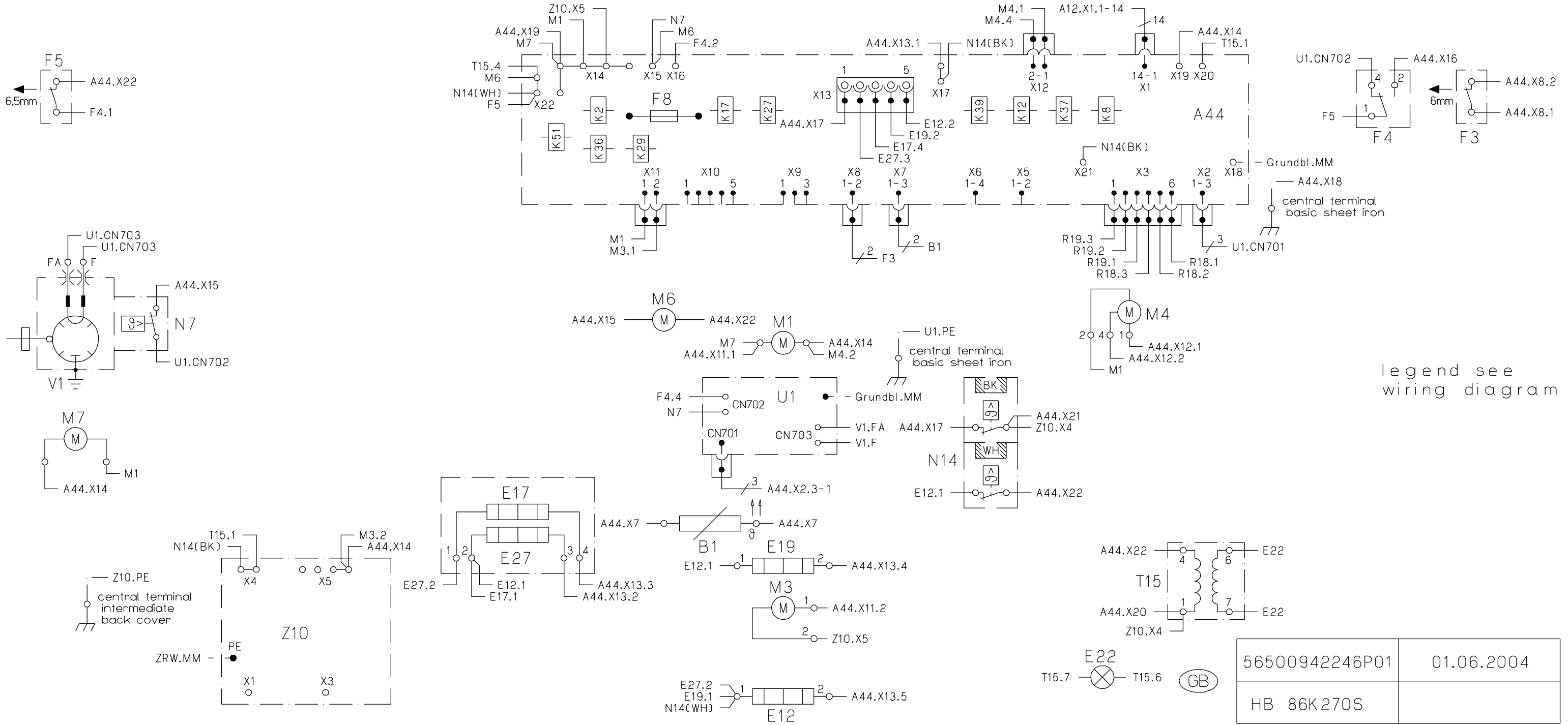

legend see wiring diagram

56500942246P01	01.06.2004
HB 86K270S	

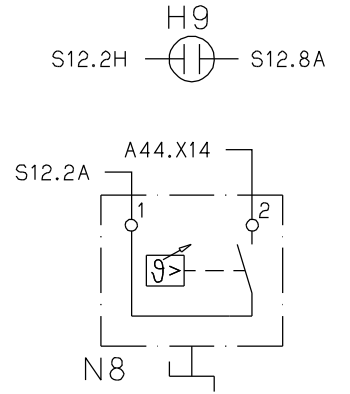
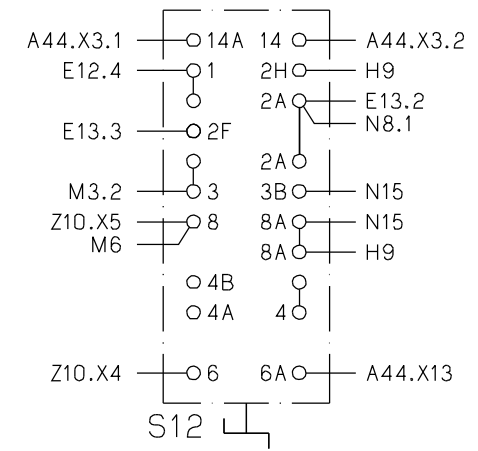
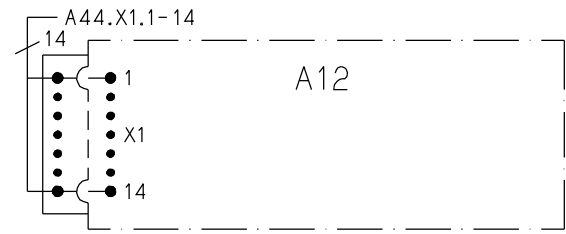

vue de l'avant  
vue de l'arrière

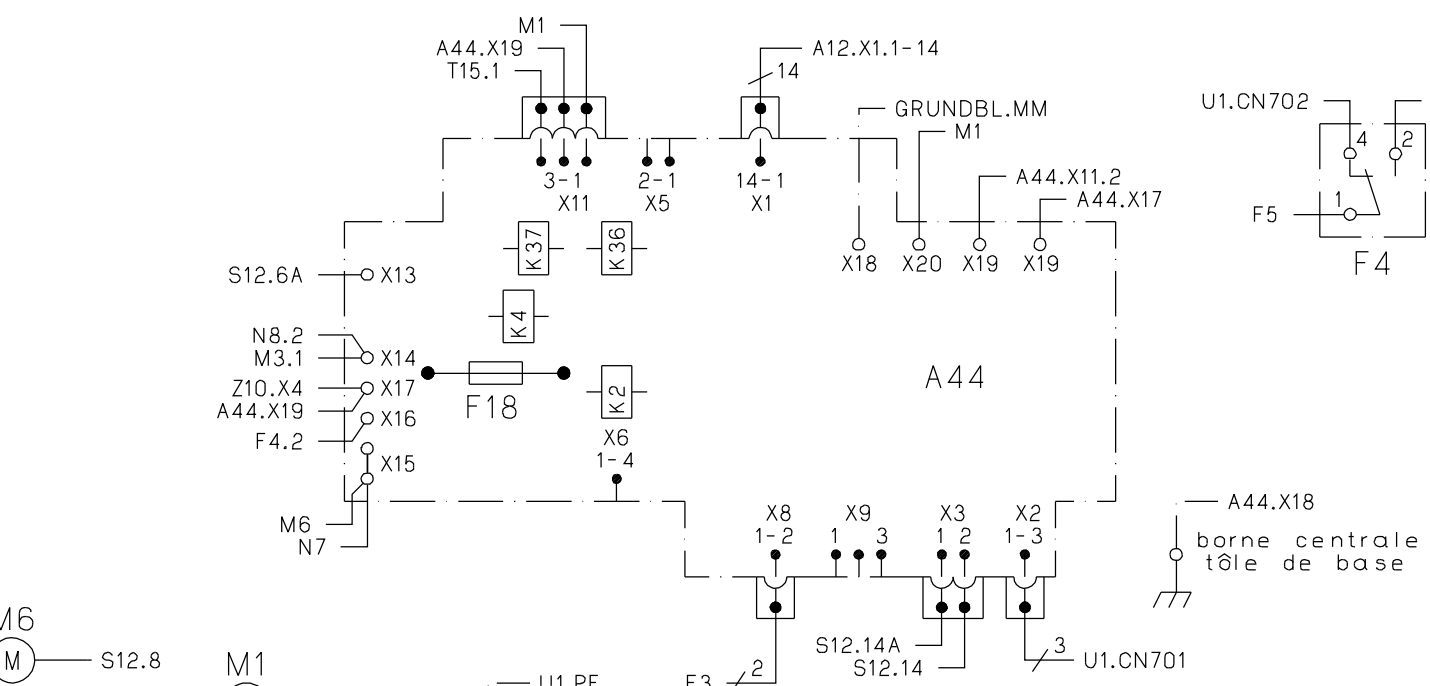
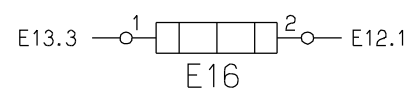
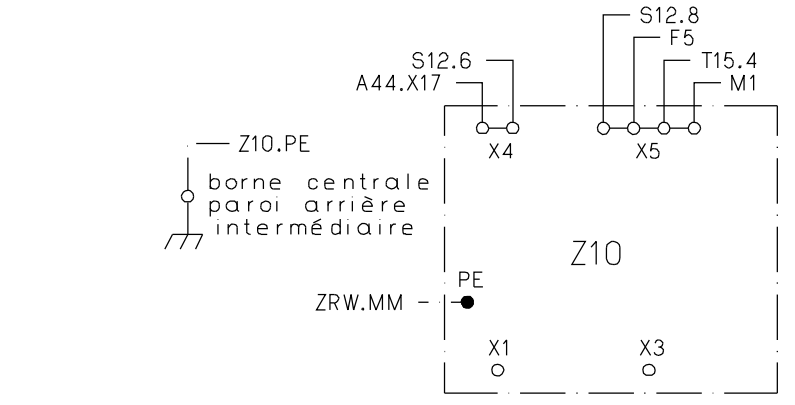
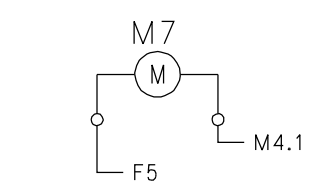
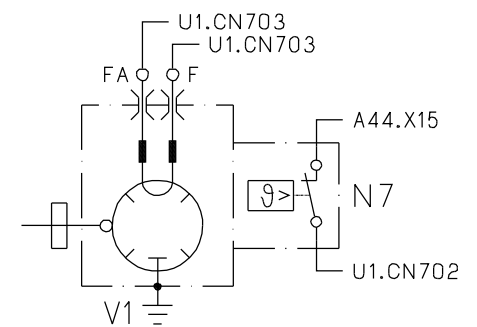
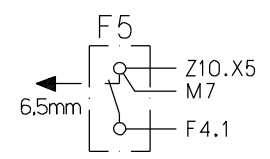

légende voir schéma de principe

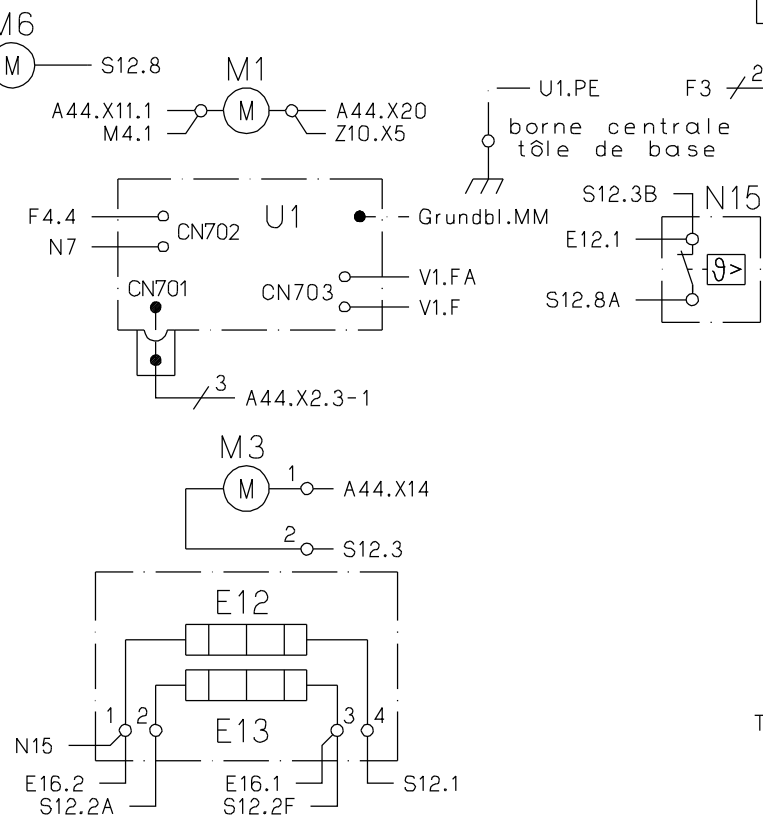

56500942241P01	03.06.2004
HB 84K550N	

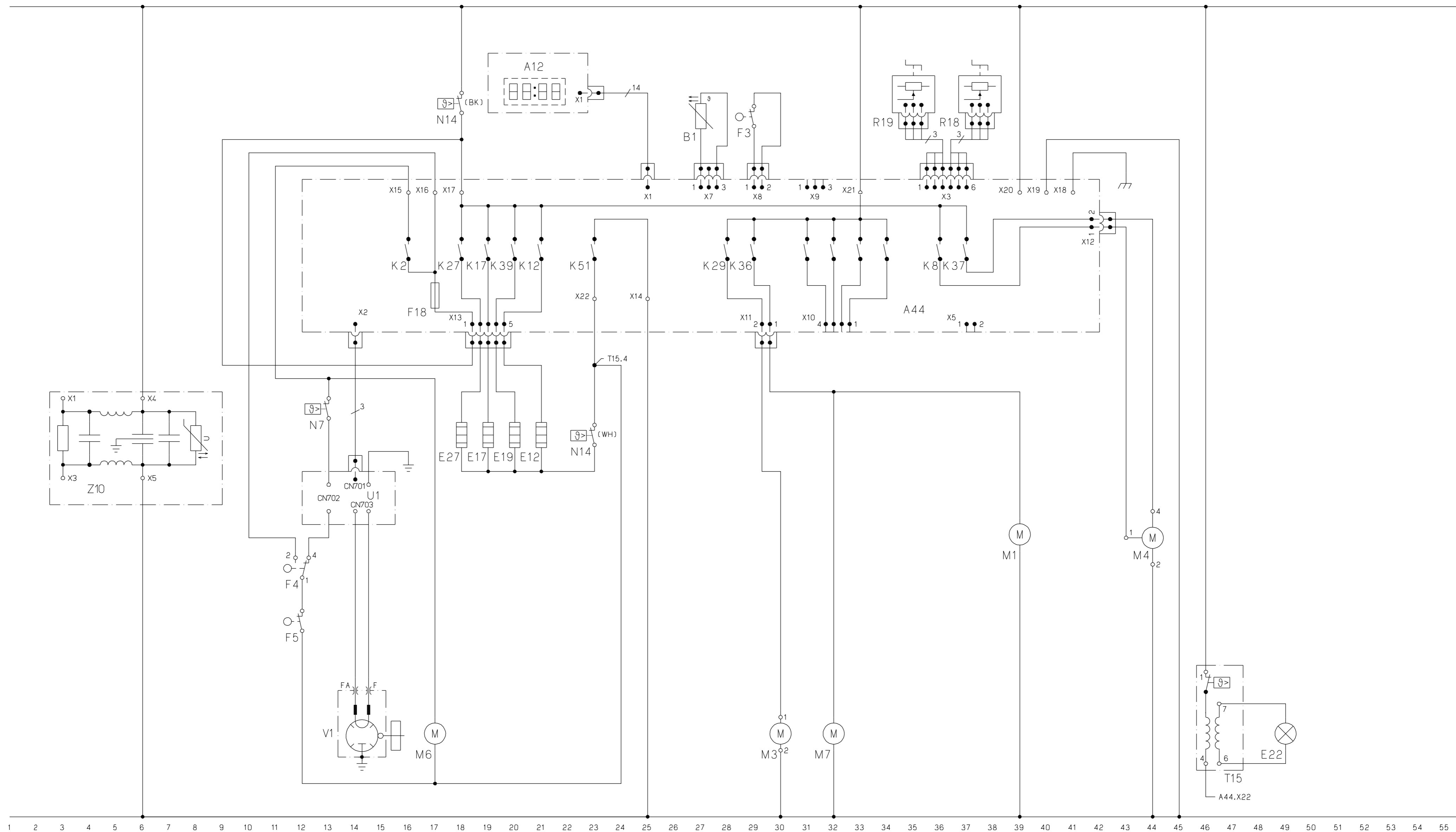

Strompfad		Strompfad		Strompfad	
A12	Eingabe-/Anzeige-Platine	19-22	K2	Leistungsrelais	16
A44	Steuerplatine	12-42	K8	Relais	36
B1	Backofentemperaturfühler	27	K12	Leistungsrelais	21
E12	Unterhitze 1500W/230V	21	K17	Leistungsrelais	19
E17	Grillheizkörper 1100W/230V	19	K27	Leistungsrelais	18
E19	Umluftheizkörper 600W/230V	20	K29	Steuerrelais	28
E22	Backofenlampe 10W	49	K36	Steuerrelais	29
E27	Grillheizkörper 1400W/230V	18	K37	Steuerrelais	37
F3	Sicherheitsschalter	29	K39	Leistungsrelais	20
F4	Sicherheitsschalter	12	K51	Leistungsrelais	23
F5	Sicherheitsschalter	12	M1	Kühlgebläsemotor	39
F18	Sicherung 8A	17	M3	Umluftmotor	30
			M4	Wrasenlüfter	44
			M6	Antennenmotor	17
			M7	Magnetronlüfter	32
			N7	Temperaturbegrenzer	13
			N14	Temperaturbegrenzer	18/23
			R18	Sollwertgeber	37/38
			R19	Sollwertgeber	34/35
			T15	Netztrafo	46/47
			U1	Inverter	12-15
			V1	Magnetron	14/15
			Z10	Funkentstörfilter	3-9

Sicherheitsschalter bei geschlossener Tür

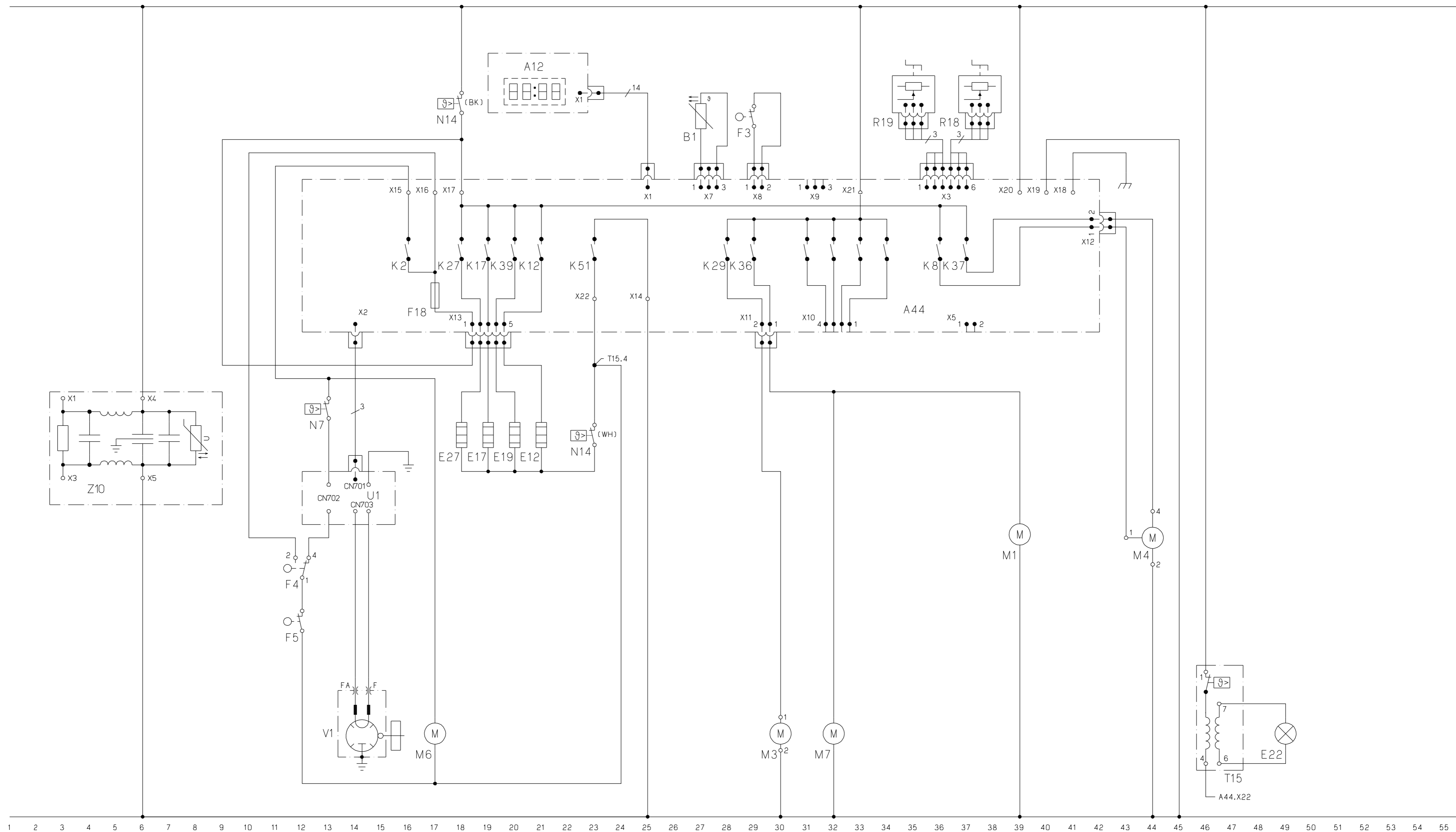

current path		current path		current path	
A12	input-/indicator-p.c.b. 19-22	K2	power relay 16	N7	temperature limiter 13
A44	control p.c.b. 12-42	K8	relay 36	N14	temperature limiter 18/23
B1	oven temperature sensor 27	K12	power relay 21	R18	set point adjuster 37/38
E12	bottom element 1500W/230V 21	K17	power relay 19	R19	set point adjuster 34/35
E17	grill element 1100W/230V 19	K27	power relay 18	T15	mains transformer 46/47
E19	circulating air heater 600W/230V 20	K29	control relay 28	U1	inverter 12-15
E22	oven lamp 10W 49	K36	control relay 29	V1	magnetron 14/15
E27	grill element 1400W/230V 18	K37	control relay 37	Z10	interference suppressor 3-9
F3	safety switch 29	K39	power relay 20	*)	R18 and R19 in Bosch appliances mutally swap
F4	safety switch 12	K51	power relay 23		
F5	safety switch 12	M1	cooling blower 39		
F18	fuse 8A 17	M3	air circulating motor 30		
		M4	vapour blower 44		
		M6	motor for antenna 17		
		M7	magnetron blower 32		

safety switches by closed door

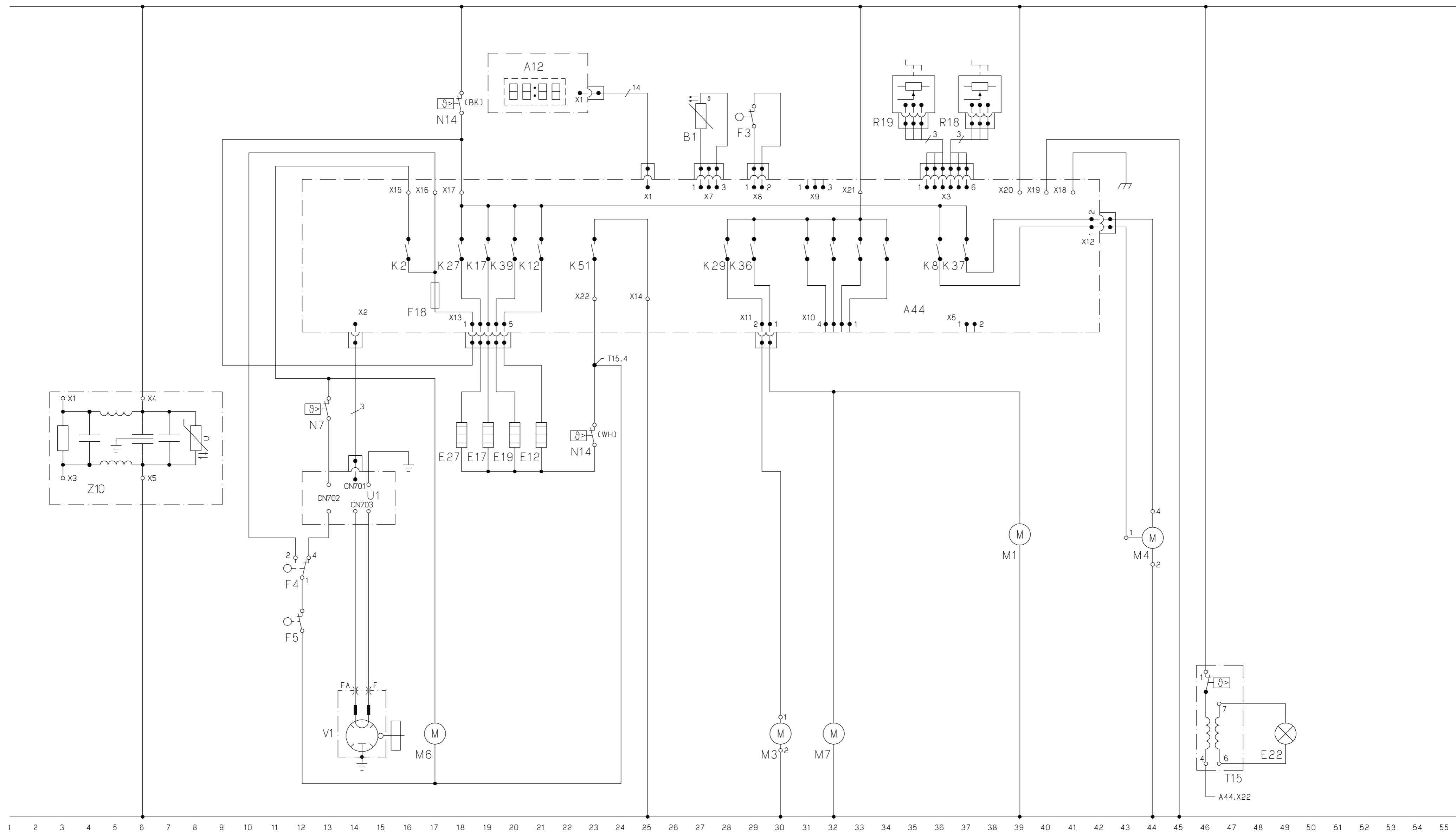

voie de courant	
A12	platine de visualisat. et de prog. 19-22
A44	platine de commande 12-42
B1	sonde de température du four 27
E12	résistance de sole 1500W/230V 21
E17	résistance grilloir 1100W/230V 19
E19	résistance circulaire 600W/230V 20
E22	éclairage du four 10W 49
E27	résistance grilloir 1400W/230V 18
F3	interrupteur de sécurité 29
F4	interrupteur de sécurité 12
F5	interrupteur de sécurité 12
F18	fusible 8A 17

voie de courant	
K2	relais de puissance 16
K8	relais 36
K12	relais de puissance 21
K17	relais de puissance 19
K27	relais de puissance 18
K29	relais de commande 28
K36	relais de commande 29
K37	relais de commande 37
K39	relais de puissance 20
K51	relais de puissance 23
M1	ventilateur 39
M3	turbine de ventilation 30
M4	ventilateur de refroidissement 44
M6	moteur d'entraînement de l'antenne 17
M7	ventilateur du magnétron 32

voie de courant	
N7	limiteur de température 13
N14	limiteur de température 18/23
R18	transmetteur de la valeur prévue 37/38
R19	transmetteur de la valeur prévue 34/35
T15	transformateur au réseau 46/47
U1	inverseur 12-15
V1	magnétron 14/15
Z10	filtre d'antiparasitage 3-9

interrupteurs de sécurité (porte fermée)

R18 et R19 dans des appareils de Bosch mutuellement échangées