

- A Touch control
- F1 Fuse 200 mA T
- L1 Coil for pan-on detection R1
- L2 Coil for pan-on detection R2
- L3 Coil for pan-on detection R3
- L4 Coil for pan-on detection R4
- L5 Coil for pan-on detection R5
- N Temperature limiter
- R1 Heating element front left
- R2 Heating element back left
- R3 Heating element back right
- R4 Heating element front middle
- R5 Heating element front right
- ST6 Service connector
- X 1 Main terminal

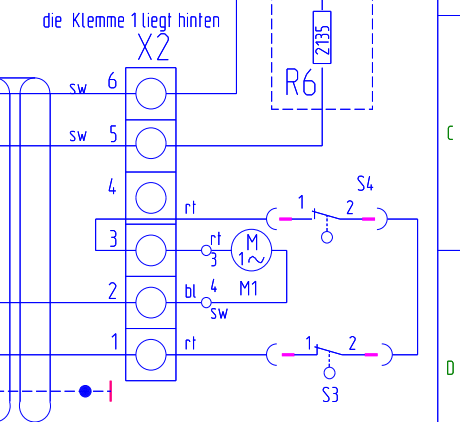

- die Klemme 1 liegt hinten
- X2 internal terminal
- R6 heating element for grill
- S1/S2 endswitch front and back
- S3/S4 pan safety switch for hob zone in
- S5/S6 safety switch for R2 / R3
- A2 powerswitch for drive in/out
- M1 drive in/out
- A1 powersupply 12V
- AC 240V 60Hz 10,4 kW

Datum	20.11.03	<p>Das Zentrum guter Küche GELSENKIRCHEN</p>	c	Steckbrücke umgesteckt	28.5.04	Feldmann	Modell-Nr.: KGCT 907.2 E-UL	Type KEM 095
Bearb.	Feldmann		b	Farben nachgetragen	10.5.04	Feldmann	Schaltbild-Nr.: 779975-4c	Blatt 1
Gepr.			And Index Pfad	Beschreibung der Änderung	Datum	Name		von 1