

- d 1 = PTC-Glied
- e 1 = Schutzschalter
- e 2 = Schalter "Gluehlampe"
- f 1 = Temperaturregler
- h 1 = Gluehlampe
- k 1 = Betriebskondensator
- l 1 = Anschlussteil
- l 2 = Tragschiene
- l 3 = Steckbuchse
- l 4 = Buchsengehaeuse (2 polig)
- m 1 = Verdichtermotor
- m 2 = Ventilatormotor
- m 3 = Umluftventilator

Strom-
pfad

3 / 4
4
2
1 / 2
2
3 / 4

3 / 4
5
6

Ⓛ

1 709 911 450	10 / 91
	50/001

d1 PTC-Glied

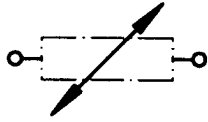

e1 Schutzschalter



e2 Schalter " Gluehlampe "



f1 Temperaturregler

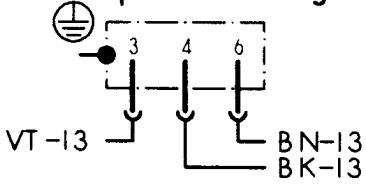

h1 Gluehlampe



k1 Betriebskondensator

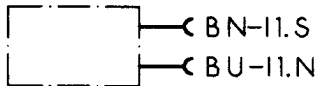

11 Anschlussteil

(DANFOSS)

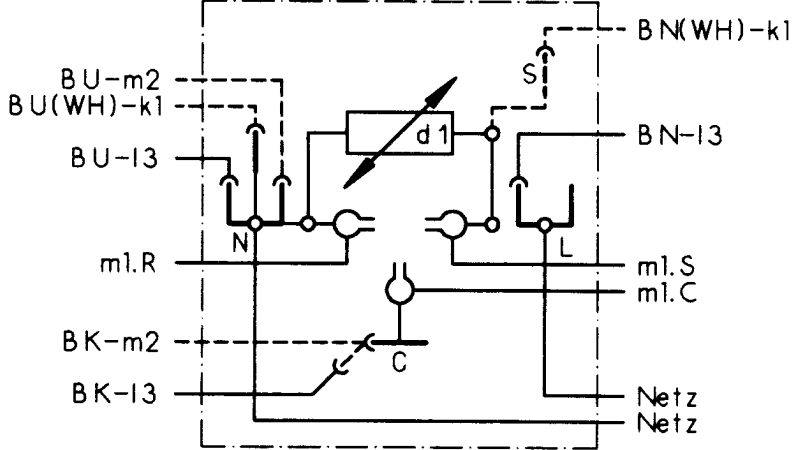

12 Tragschiene

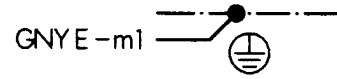

13 Steckbuchse

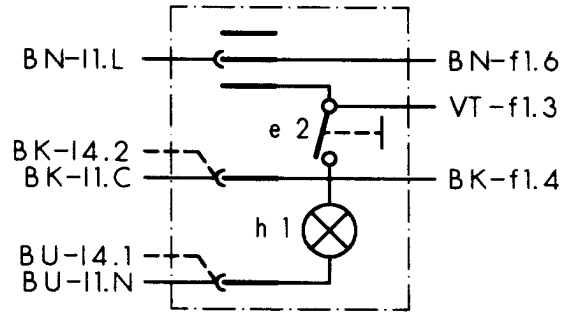

m1 Verdichter-Motor

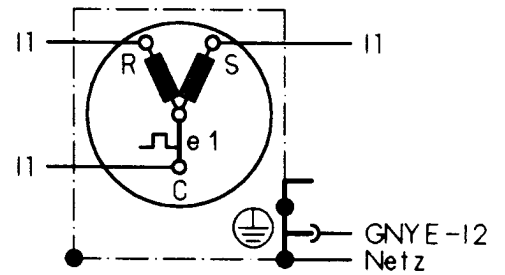

m2 Ventilator-Motor



m3 Umluftventilator + 14 Buchsengehaeuse

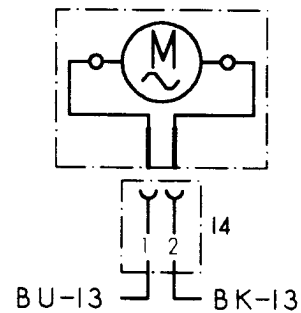

Farbe	Kurzzeichen nach DIN/IEC 757
schwarz	BK
braun	BN
rot	RD
orange	OG
gelb	YE
gruen	GN
blau	BU
violett	VT
grau	GY
weiss	WH
rosa	PK
gold	GD
fuerkis	TQ
silber	SR

Ⓚ

1 709 911 450	01 / 92
	50/002