

bu.B2.2, bu.B4.2, bu.K2.X3.2, bu.B3.2
SP2

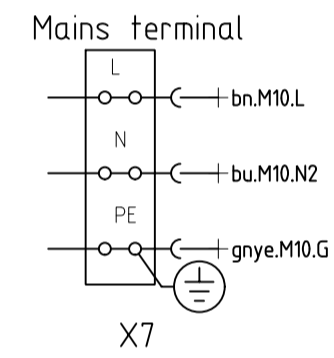

Electronic module compressor

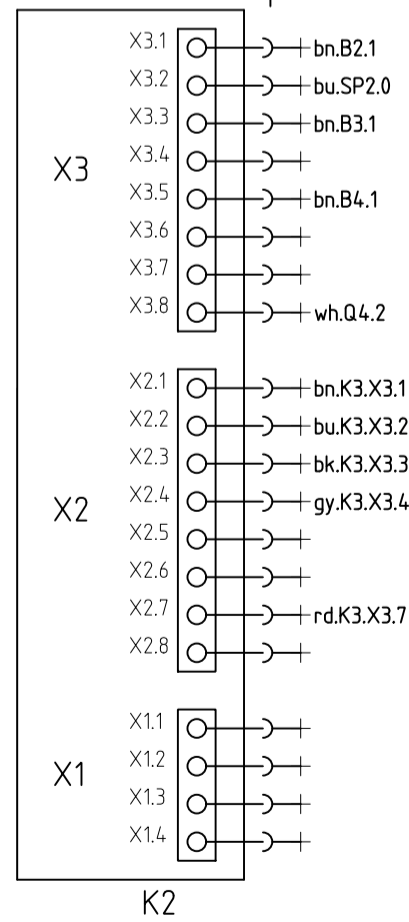

Power supply unit compressor

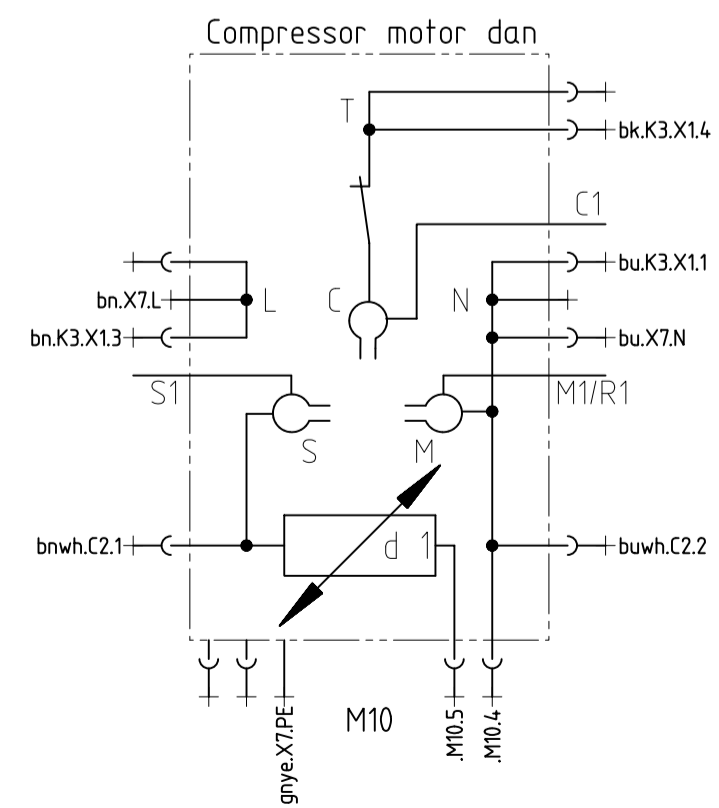
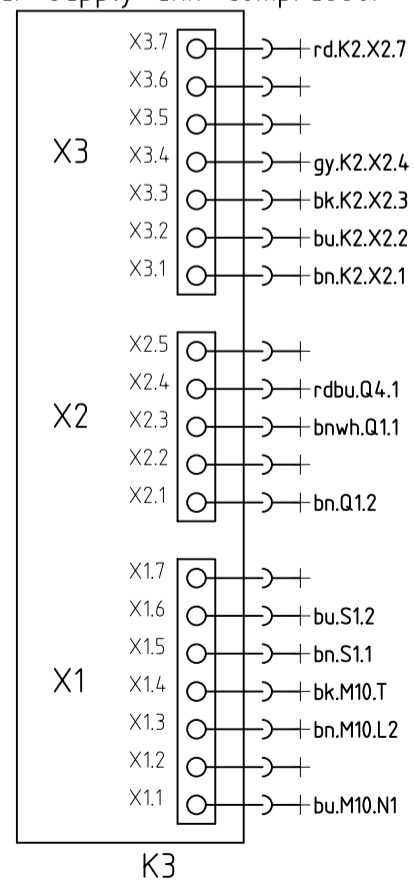

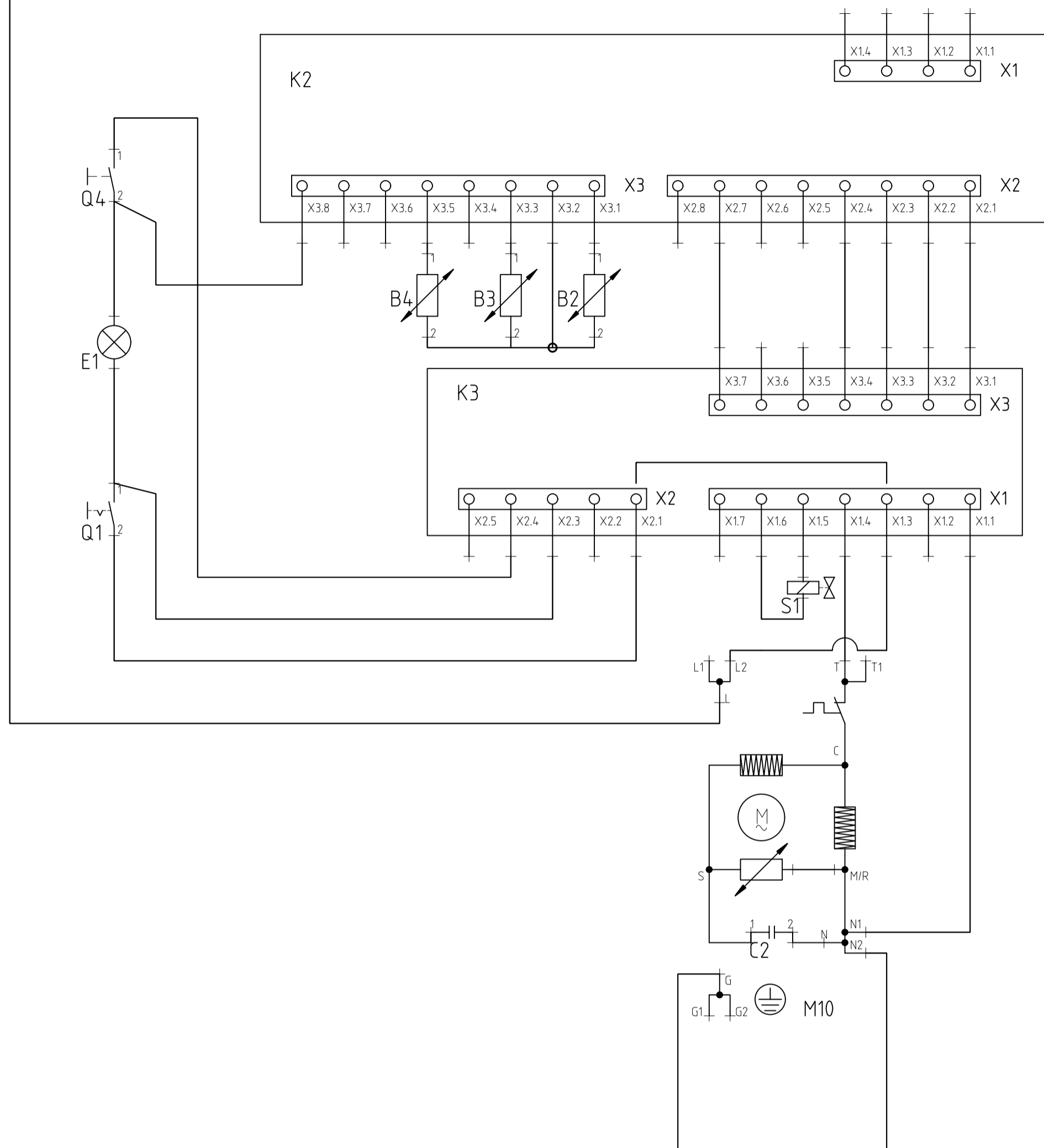

1 2 3 4 5 6 7 8 9 10 11 12 13 14 15 16 17 18 19 20 21 22 23 24 25 26 27 28 29 30 31 32 33 34 35 36 37 38 39 40 41 42 43 44 45 46 47 48 49 50 51 52 53 54 55

REF	Components	Path
B2	Air temperature sensor	25
B3	Air temperature sensor	23
B4	Air temperature sensor	21
E1	Lamp	14
K2	Electronic module compressor	18-25,27-34
K3	Power supply unit compressor	22-26,28-34
M10	Compressor motor dan	28-32
Q1	Main switch	14
Q4	Switch	14
S1	Solenoid valve 3way	30
SP2		24
X7	Mains terminal	1

The reproduction, transmission or use of this document or its contents is not permitted without express written authority. Offenders will be liable for damages. All rights including rights created by patent grant or registration of a utility model or design are reserved. Copyright reserved.