

bearbeitet von: K.H.Hiby

Telefon: (0209) 401732

Datum: 27.01.1997

Nr.21

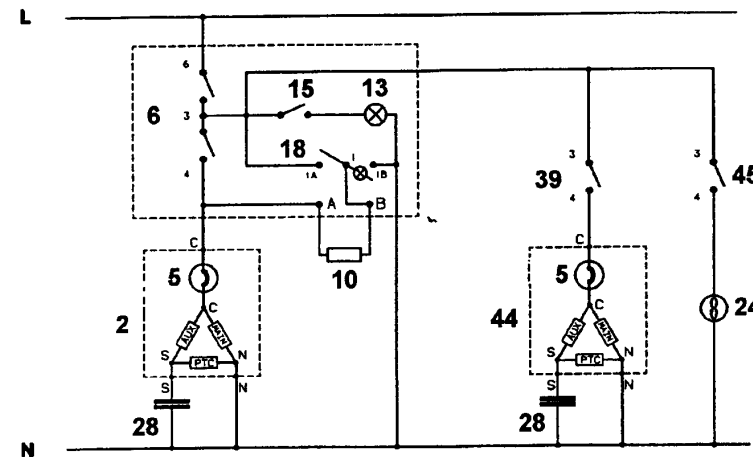
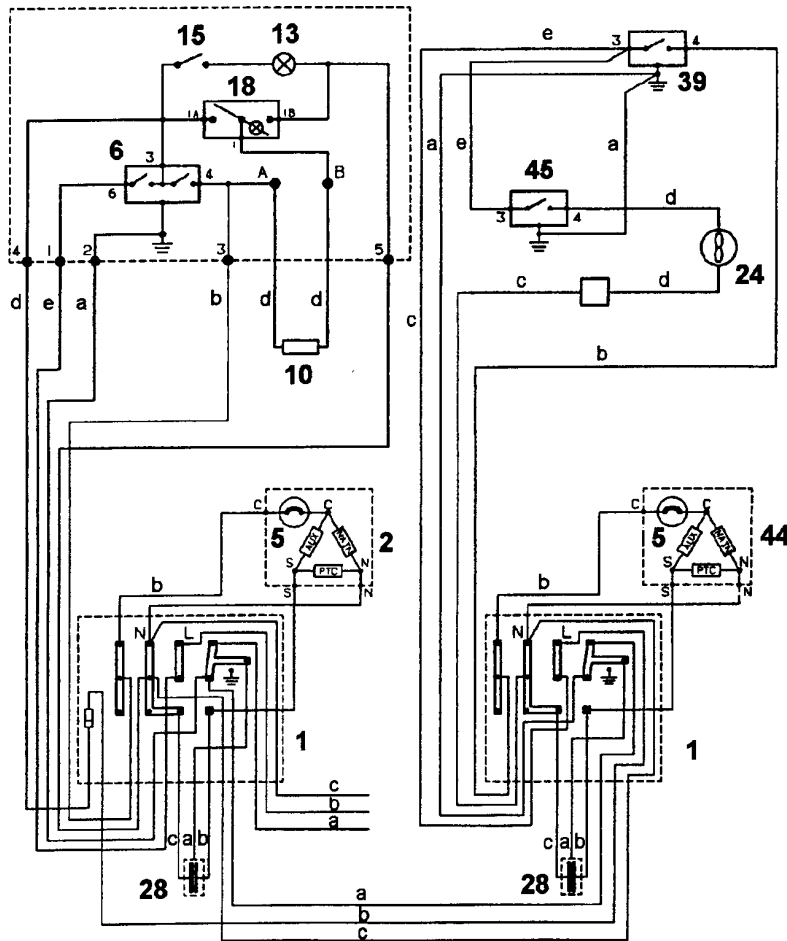

- | | | |
|-------------------------------|---------------------------------------|--------------|
| 1. Klemmleiste | 18. Ausgleich-Heizwiderstand Schalter | a Gelb-Gruen |
| 2. Verdichter, Kuehlschrank | 24. Ventilator | b Braun |
| 5. Motorschutz | 28. Kondensator | c Blau |
| 6. Kuehlschrank-Thermostat | 39. 0 Zone Thermostat | d Weiss |
| 10. Ausgleich-Heizwiderstand | 44. 0 Zone Kompressor | e Schwarz |
| 13. Kuehlschranklampe | 45. Ventilator-Thermostat | f Grau |
| 15. Kuehlschrank Tuerschafter | | g Rot |